



FLOW CONTROL (AND CHECK) VALVES

FG -01/02/03/06/10 (1/8,1/4,3/8,3/4,1-1/4)
FCG

PILOT OPERATED FLOW CONTROL (AND CHECK) VALVES

FHG -02/03/06/10 (1/4,3/8,3/4,1-1/4)
FHCG

Sub-plate Mounting

FLOW CONTROLS

Up to 21 MPa (3050 PSI), 500 L/min (132 U.S.GPM)

Flow Control and Check Valves Page 2

These valves are pressure and temperature compensating type valves and maintain a constant flow rate independent of change in system pressure (load) and temperature (viscosity of the fluid). They control flow rate of the hydraulic circuit and eventually control speed of the actuator precisely.

Valves with an integral check valve allow a controlled flow and reverse free flow. Repeated resetting can be made easily with a digital readout.

Pilot Operated Flow Control and Check Valves Page 14

Flow control of these valves is continuously made by a hydraulically operated pilot piston mechanism which controls opening area of the orifice of the valve. With the use of these valves, shockless operation either in acceleration or deceleration can be obtained. With the compensator for the pressure and temperature, stable flow control can be obtained regardless of the changes in the pressure (load) and temperature (oil viscosity).

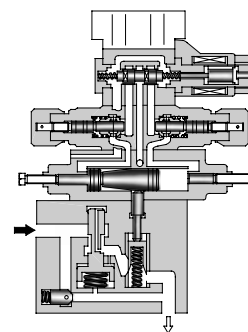
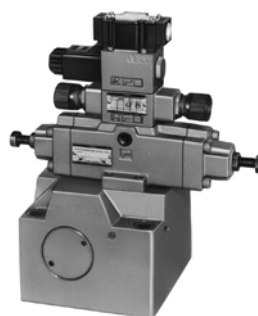
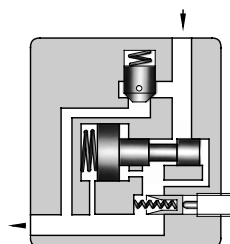

FG

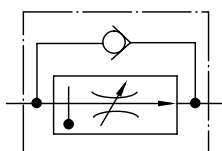

FCG

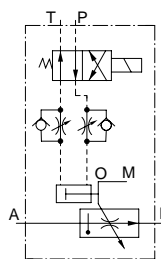

FHG

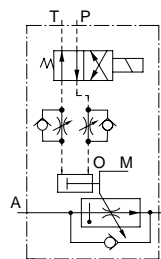

FHCG

Hydraulic Fluids

Fluid Types

Any type of hydraulic fluids listed in the table below can be used.

Petroleum base oils	Use fluids equivalent to ISO VG 32 or VG 46.
Synthetic fluids	Use phosphate ester or polyol ester fluid. When phosphate ester fluid is used, prefix "F-" to the model number because the special seals (fluororubber) are required to be used.
Water containing fluids	Use water-glycol fluid.

Note: For use with hydraulic fluids other than those listed above, please consult your Yuken representatives in advance.

Recommended Viscosity and Oil Temperatures

Viscosity ranging between 15 - 400 mm²/s (77 - 1800 SSU).

Oil temperatures between -15/+70°C (5 - 158°F).

Use hydraulic fluids which satisfy the recommended viscosity and oil temperatures given above.

Control of Contamination

Due caution must be paid to maintaining control over contamination of the hydraulic fluids which may otherwise lead to breakdowns and shorten the life of the valves. Please maintain the degree of contamination within NAS 1638-Grade 12. Use 25 μm or finer line filter.



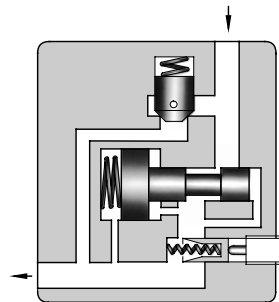

Specifications

Model Numbers	Max. Metred Flow Capacity L/min (U.S.GPM)	Min. Metred Flow Capacity L/min (U.S.GPM)	Max. Operating Pressure MPa (PSI)	Approx. Mass kg (lbs.)
FG -01-4 FCG -01-8-* -11*	8 (2.1)	0.02 (.005) {0.04 (.011)} *	14 (2030)	1.3 (2.9)
FG -02-30-* -30*	30 (7.9)	0.05 (.013)	21 (3050)	3.8 (8.4)
FG -03-125-* -30*	125 (33)	0.2 (.053)		7.9 (17.4)
FG -06-250-* -30*	250 (66)	2 (.53)		23 (50.7)
FG -10-500-* -30*	500 (132)	4 (1.06)		52 (115)

★ The figures in the brace are for pressures above 7 MPa (1020 PSI).

Model Number Designation

F-	FC	G	-01	-8	-N	-11	*
Special Seals	Series Number	Type of Mounting	Valve Size	Max. Metred Flow Capacity L/min (U.S.GPM)	Pres. Compensator Stroke Adjustment	Design Number	Design Standards
F: Special Seals for Phosphate Ester Type Fluids (Omit if not required)	F: Flow Control Valves FC: Flow Control and Check Valves	G: Sub-plate Mounting	01	4 : 4 (1.06) 8 : 8 (2.1)	N: Applicable only for Pres. Compensator Stroke Adjustment (Option - Omit if not required)	11	Refer to ★
			02	30 : 30 (7.9)		30	
			03	125 : 125 (33)		30	
			06	250 : 250 (66)		30	
			10	500 : 500 (132)		30	

★ Design Standards: None Japanese Standard "JIS" and European Design Standard 90 N. American Design Standard

Attachment

● Mounting Bolts

Valve Model Numbers	Socket Head Cap Screw		Qty.
	Japanese Std. "JIS" & European Design Std.	N. American Design Std.	
FG/FCG-01	M5 × 55 Lg.	No.10-24 UNC × 2-1/4 Lg.	4
FG/FCG-02	M8 × 50 Lg.	5/16-18 UNC × 2 Lg.	4
FG/FCG-03	M10 × 75 Lg.	3/8-16 UNC × 3 Lg.	4
FG/FCG-06	M16 × 130 Lg.	5/8-11 UNC × 5 Lg.	4
FG/FCG-10	M20 × 160 Lg.	3/4-10 UNC × 6-1/2 Lg.	4

Graphic Symbols

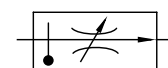

FG

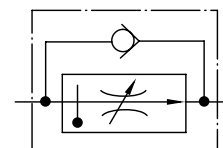

FCG

Option

● Pres. compensator stroke adjustment

Can reduce jumping at the start of the actuator.

■ Sub-plate

Valve Model Numbers	Japanese Standard "JIS"		European Design Std.		N. American Design Std.		Approx. Mass kg (lbs.)
	Sub-plate Model No.	Thread Size	Sub-plate Model No.	Thread Size	Sub-plate Model No.	Thread Size	
FG FCG ⁻⁰¹	FGM-01X-10	Rc 1/4	FGM-01X-1080	1/4 BSP.F	FGM-01X-1090	1/4 NPT	0.8 (1.8)
FG FCG ⁻⁰²	FGM-02-20	Rc 1/4	FGM-02-2080	1/4 BSP.F	FGM-02-2090	1/4 NPT	2.3 (5.1)
	FGM-02X-20	Rc 3/8	FGM-02X-2080	3/8 BSP.F	FGM-02X-2090	3/8 NPT	2.3 (5.1)
	FGM-02Y-20	Rc 1/2	FGM-02Y-2080	1/2 BSP.F	FGM-02Y-2090	1/2 NPT	3.1 (6.8)
FG FCG ⁻⁰³	FGM-03-20	Rc 3/8	FGM-03-2080	3/8 BSP.F	FGM-03-2090	3/8 NPT	3.9 (8.6)
	FGM-03X-20	Rc 1/2	FGM-03X-2080	1/2 BSP.F	FGM-03X-2090	1/2 NPT	3.9 (8.6)
	FGM-03Y-20	Rc 3/4	FGM-03Y-2080	3/4 BSP.F	FGM-03Y-2090	3/4 NPT	5.7 (12.6)
	FGM-03Z-20	Rc 1	FGM-03Z-2080	1 BSP.F	FGM-03Z-2090	1 NPT	5.7 (12.6)
FG FCG ⁻⁰⁶	FGM-06X-20	Rc 1	FGM-06X-2080	1 BSP.F	FGM-06X-2090	1 NPT	12.5 (27.6)
	FGM-06Y-20	Rc 1-1/4	FGM-06Y-2080	1-1/4 BSP.F	FGM-06Y-2090	1-1/4 NPT	16 (35.3)
	FGM-06Z-20	Rc 1-1/2	FGM-06Z-2080	1-1/2 BSP.F	FGM-06Z-2090	1-1/2 NPT	16 (35.3)
FG FCG ⁻¹⁰	FGM-10Y-20 [*]	1-1/2, 2	FGM-10Y-20 [*]	1-1/2, 2	FGM-10Y-2090 [*]	1-1/2, 2	37 (81.6)

● Sub-plates are available. Specify the sub-plate model number from the table above. When sub-plates are not used, the mounting surface should have a good machined finish.

★FGM-10Y is special type sub-plate to be used with pipe flange. When ordering FGM-10Y, specify pipe flange kit in addition to FGM-10Y referring to F3 pipe flange kits Catalogue (No. Pub. EC-3001).

■ Instructions

● Min. required pressure difference

The minimum differential pressure between inlet and outlet port is required to obtain the optimum pressure compensation. It varies according to the flow rate to be set. For details, please refer to the performance curves.

● Free flow

Check valve pressure drops vary with flow rates. If models with check valves are used, see free flow pressure drop characteristics.

● Flow adjustment

[F*G-01]

Loosen the locking screw and turn the flow adjustment dial clockwise for increase, and anti-clockwise for decrease. The dial makes about 4 revolutions from zero to full flow and the valve opening is indicated on the revolution indicator. (Refer to characteristics of "Metred Flow vs. Dial Position").

After flow adjustments, tighten the locking screw.

[F*G-02, 03, 06, 10]

Loosen the locking screw and turn the flow adjustment handle clockwise for increase, and anti-clockwise for decrease. Open condition is indicated in digital-scale in built-in revolution indicator (Refer to the characteristics of "Metred Flow vs. Dial Position").

After flow adjustments, tighten the locking screw.

● Line filter

To carry out flow adjustments by as small degree as 2 L/min (.53 U.S.GPM) or less, be sure to use a line filter of 10 μm or finer and install it near the valve inlet.



FG/FCG-01-**-**-11/1190

DIMENSIONS IN
MILLIMETRES (INCHES)

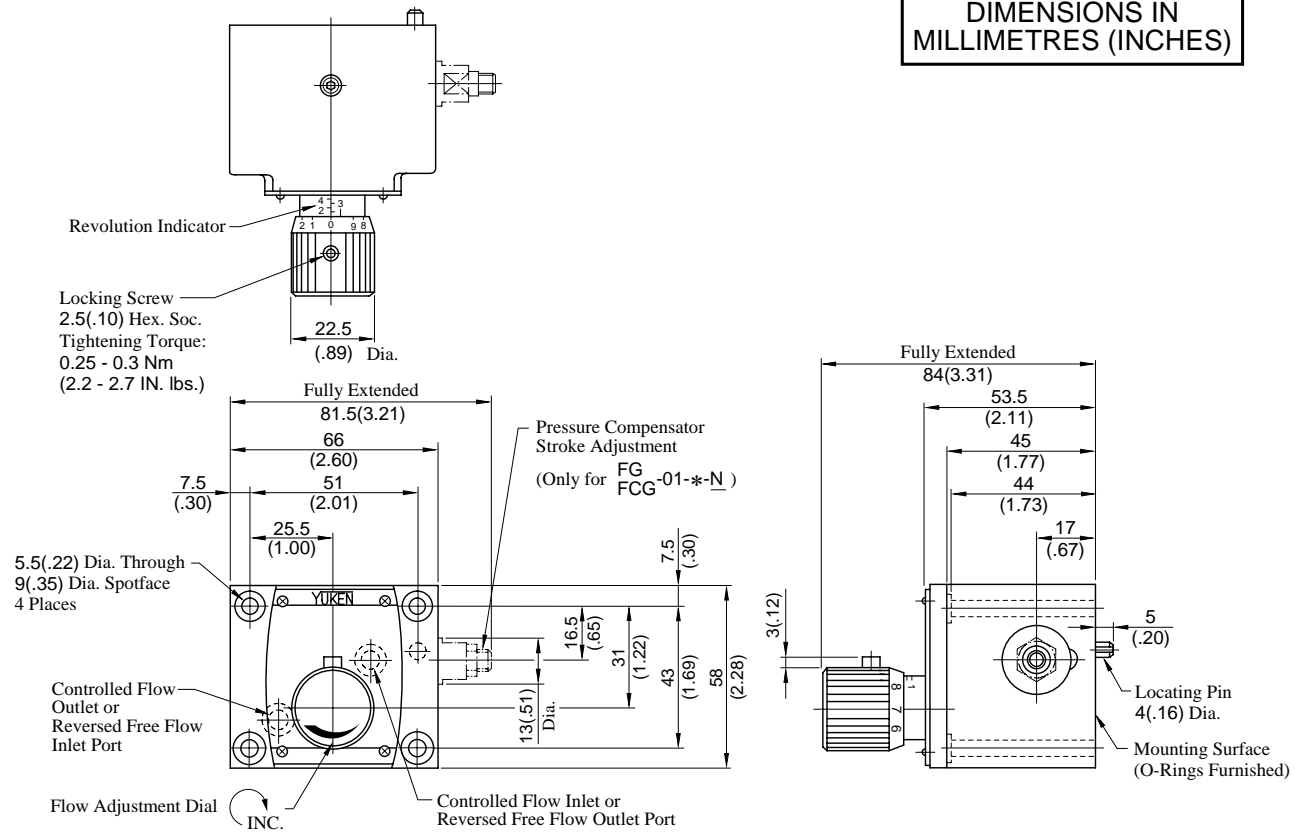

FG/FCG-02-30-**-30/3090, FG/FCG-03-125-**-30/3090

Mounting surface:
F*G-02: ISO 6263-AB-06-4-B
F*G-03: ISO 6263-AK-07-2-A

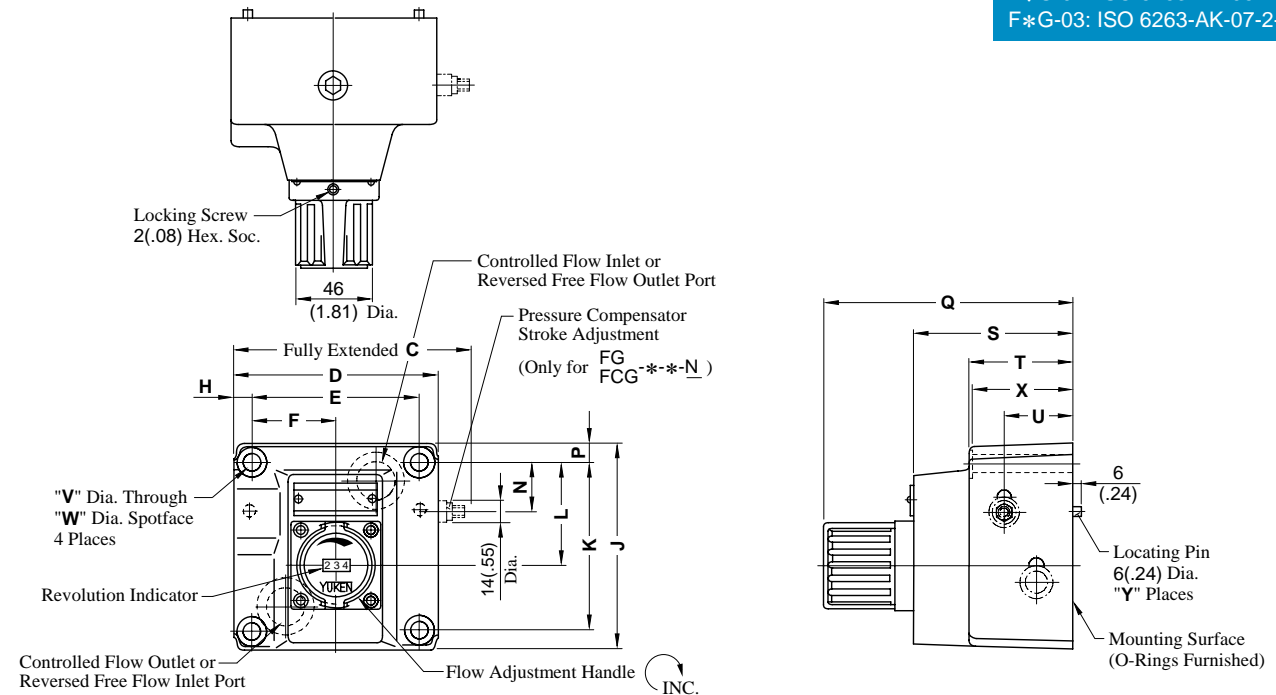

Model No.	Dimensions mm (Inches)																	Y
	C	D	E	F	H	J	K	L	N	P	Q	S	T	U	V	W	X	
FG FCG-02	116 (4.57)	96 (3.78)	76.2 (3.00)	38.1 (1.50)	9.9 (.39)	104.5 (4.11)	82.6 (3.25)	44.3 (1.74)	24 (.94)	9.9 (.39)	123 (4.84)	69 (2.72)	40 (1.57)	23 (.91)	8.8 (.35)	14 (.55)	39 (1.54)	1
FG FCG-03	145 (5.71)	125 (4.92)	101.6 (4.00)	50.8 (2.00)	11.7 (.46)	125 (4.92)	101.6 (4.00)	61.8 (2.43)	29.8 (1.17)	11.7 (.46)	152 (5.98)	98 (3.86)	64 (2.52)	41 (1.61)	11 (.43)	17.5 (.69)	63 (2.48)	2

FG/FCG-06-250-*-30/3090
FG/FCG-10-500-*-30/3090

Mounting surface:
F*G-06: ISO 6263-AP-08-2-A

DIMENSIONS IN
MILLIMETRES (INCHES)

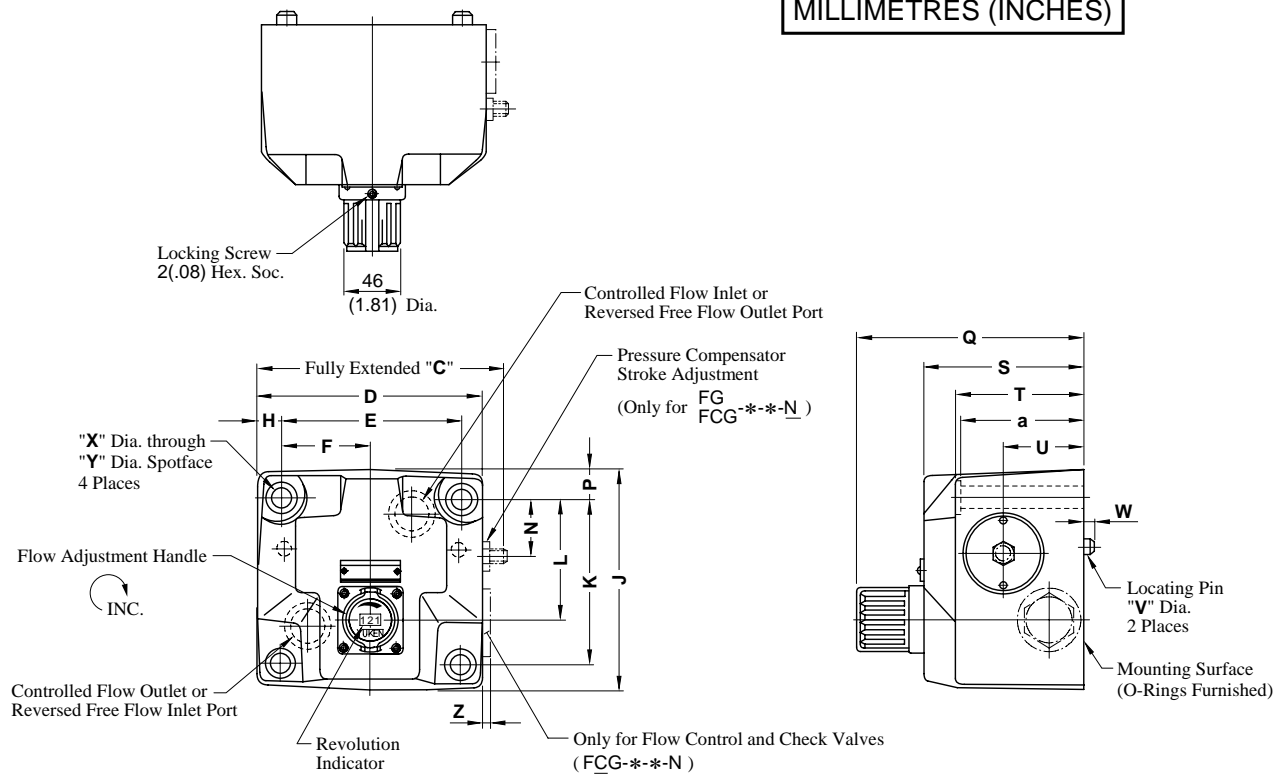

Model No.	Dimensions mm (Inches)																			
	C	D	E	F	H	J	K	L	N	P	Q	S	T	U	V	W	X	Y	Z	a
FG FCG-06	198 (7.80)	180 (7.09)	146.1 (5.75)	73 (2.87)	17 (.67)	174 (6.85)	133.4 (5.25)	99 (3.90)	44 (1.73)	20.3 (.80)	184 (7.24)	130 (5.12)	105 (4.13)	65 (2.56)	16 (.63)	7 (.28)	17.5 (.69)	26 (1.02)	9 (.35)	103 (4.06)
FG FCG-10	267 (10.51)	244 (9.61)	196.9 (7.75)	98.5 (3.88)	23.5 (.93)	228 (8.98)	177.8 (7.00)	144.5 (5.69)	61 (2.40)	25 (.98)	214 (8.43)	160 (6.30)	137 (5.39)	85 (3.35)	18 (.71)	10 (.39)	21.5 (.85)	32 (1.26)	7.5 (.30)	135 (5.31)



FGM-01X-10/1080/1090

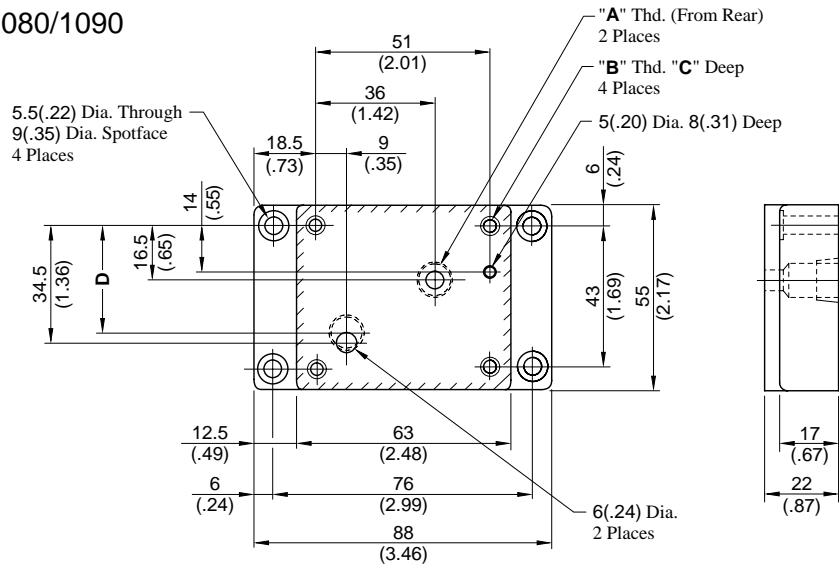

Sub-plate Model Numbers	"A" Thd.	"B" Thd.	C	D
FGM-01X-10	Rc 1/4	M5	14 (.55)	34.5 (1.36)
FGM-01X-1080	1/4 BSP.F	M5	14 (.55)	30.0 (1.18)
FGM-01X-1090	1/4 NPT	No.10-24 UNC	15 (.59)	34.5 (1.36)

**DIMENSIONS IN
MILLIMETRES (INCHES)**

02
FGM-02X-20/2080/2090
02Y

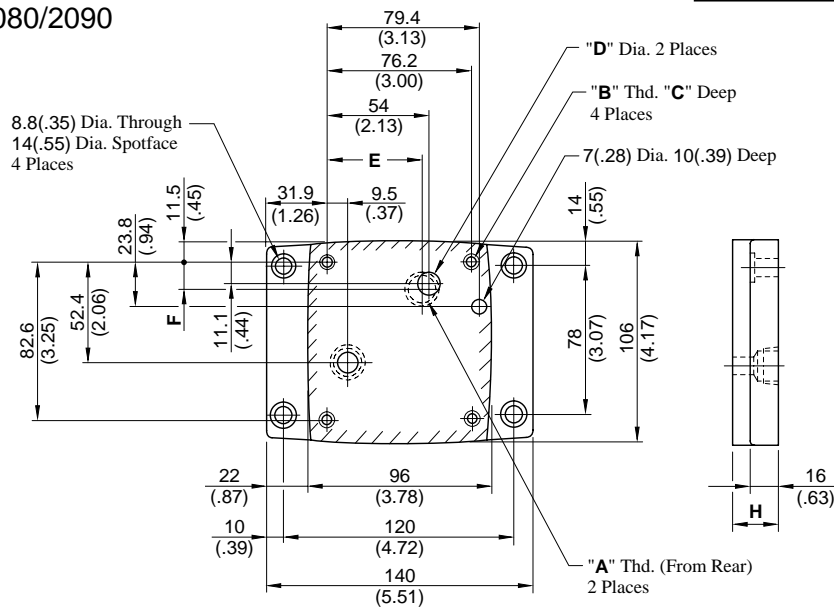

Sub-plate Model Numbers	"A" Thd.	"B" Thd.	C	D	E	F	H
FGM-02-20	Rc 1/4	M8	14 (.55)	11.0 (.43)	54 (2.13)	11.1 (.44)	25 (.98)
FGM-02-2080	1/4 BSP.F		14 (.55)	11.7 (.46)			
FGM-02-2090	1/4 NPT	5/16-18 UNC	18 (.71)	11.0 (.43)			
FGM-02X-20	Rc 3/8	M8	14 (.55)	14.0 (.55)			
FGM-02X-2080	3/8 BSP.F		14 (.55)	15.2 (.60)			
FGM-02X-2090	3/8 NPT		5/16-18 UNC	18 (.71)			
FGM-02Y-20	Rc 1/2	M8	14 (.55)	14.0 (.55)	51 (2.01)	14 (.55)	35 (1.38)
FGM-02Y-2080	1/2 BSP.F		14 (.55)	15.0 (.59)			
FGM-02Y-2090	1/2 NPT		5/16-18 UNC	18 (.71)			

03
FGM-03X-20/2080/2090
03Y
03Z

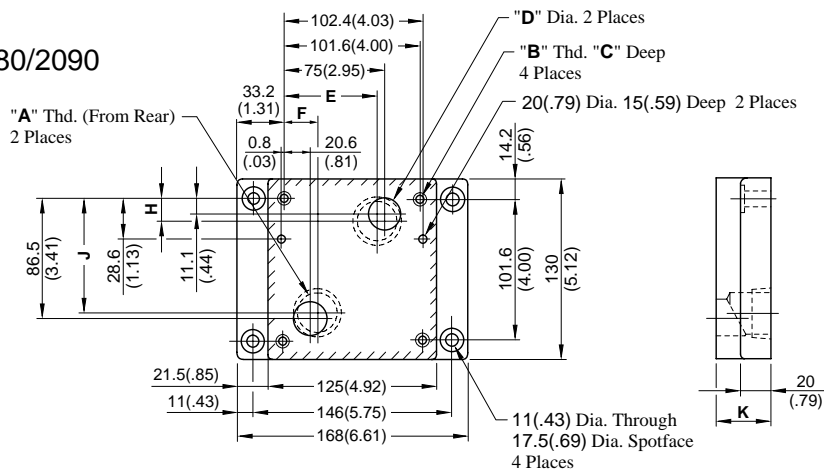

Sub-plate Model Numbers	"A" Thd.	"B" Thd.	C	D	E	F	H	J	K
FGM-03-20	Rc 3/8	M10	18 (.71)	14.0 (.55)	75 (2.95)	20.6 (.81)	11.1 (.44)	86.5 (3.41)	25 (.98)
FGM-03-2080	3/8 BSP.F			15.0 (.59)					
FGM-03-2090	3/8 NPT	3/8-16 UNC	21 (.83)	14.0 (.55)	75 (2.95)	20.6 (.81)	11.1 (.44)	86.5 (3.41)	25 (.98)
FGM-03X-20	Rc 1/2	M10	18 (.71)	17.5 (.69)					
FGM-03X-2080	1/2 BSP.F			19.0 (.75)					
FGM-03X-2090	1/2 NPT	3/8-16 UNC	21 (.83)	17.5 (.69)	70 (2.76)	25.6 (1.01)	16.1 (.63)	81.5 (3.21)	40 (1.57)
FGM-03Y-20	Rc 3/4	M10	18 (.71)	23.0 (.91)					
FGM-03Y-2080	3/4 BSP.F				21 (.83)				
FGM-03Y-2090	3/4 NPT	3/8-16 UNC	21 (.83)	70 (2.76)		25.6 (1.01)	16.1 (.63)	81.5 (3.21)	40 (1.57)
FGM-03Z-20	Rc 1	M10	18 (.71)						
FGM-03Z-2080	1 BSP.F			21 (.83)					
FGM-03Z-2090	1 NPT	3/8-16 UNC	21 (.83)		70 (2.76)	25.6 (1.01)	16.1 (.63)	81.5 (3.21)	40 (1.57)

DIMENSIONS IN
MILLIMETRES (INCHES)

06X
FGM-06Y-20/2080/2090
06Z

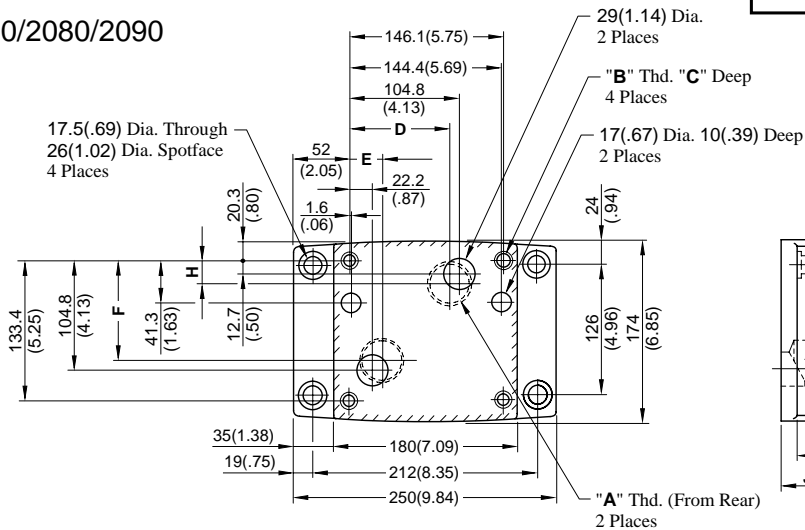

Sub-plate Model Numbers	"A" Thd.	"B" Thd.	C	D	E	F	H	J	K
FGM-06X-20	Rc 1	M16	30 (1.18)	104.8 (4.13)	22.2 (.87)	104.8 (4.13)	18 (.71)	45 (1.77)	35 (1.38)
FGM-06X-2080	1 BSP.F								
FGM-06X-2090	1 NPT	5/8-11 UNC	35 (1.38)	99 (3.90)	34 (1.34)	99 (3.90)	23 (.91)	60 (2.36)	40 (1.57)
FGM-06Y-20	Rc 1-1/4	M16	30 (1.18)						
FGM-06Y-2080	1-1/4 BSP.F			35 (1.38)					
FGM-06Y-2090	1-1/4 NPT	5/8-11 UNC	35 (1.38)		99 (3.90)	34 (1.34)	99 (3.90)	23 (.91)	60 (2.36)
FGM-06Z-20	Rc 1-1/2	M16	30 (1.18)						
FGM-06Z-2080	1-1/2 BSP.F			35 (1.38)					
FGM-06Z-2090	1-1/2 NPT	5/8-11 UNC	35 (1.38)		99 (3.90)	34 (1.34)	99 (3.90)	23 (.91)	60 (2.36)

FGM-10Y-20/2090

DIMENSIONS IN
MILLIMETRES (INCHES)

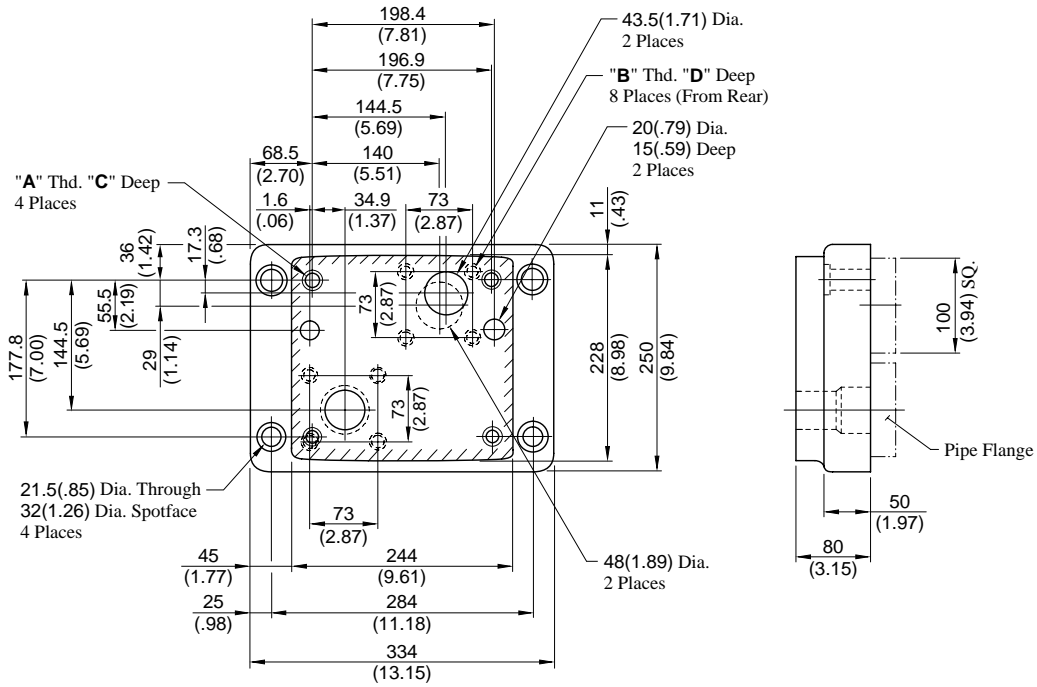

Sub-plate Model Numbers	"A" Thd.	"B" Thd.	C	D
FGM-10Y-20	M20	M16	32 (1.26)	32 (1.26)
FGM-10Y-2090	3/4-10 UNC	5/8-11 UNC	32 (1.26)	34 (1.34)

Metred Flow vs. Differential Pressure

Metred Flow vs. Viscosity

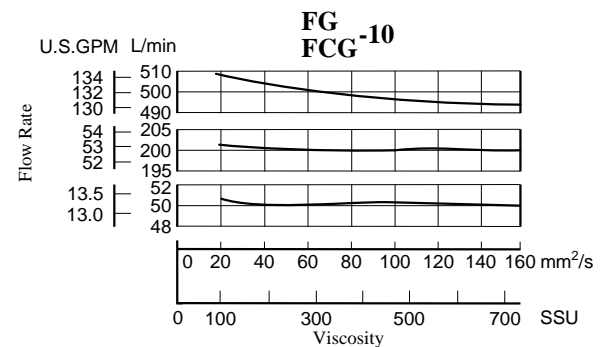
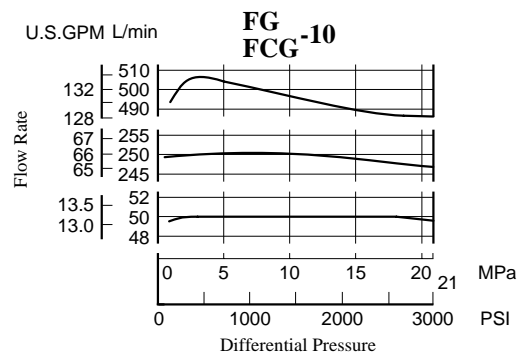
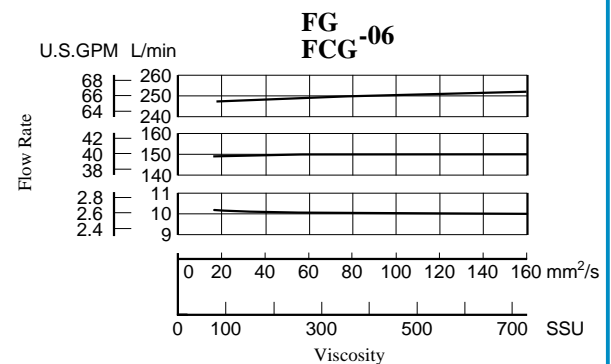
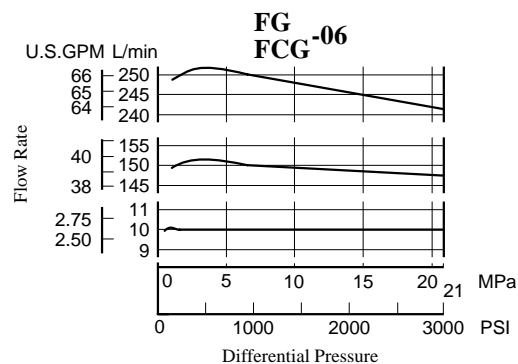
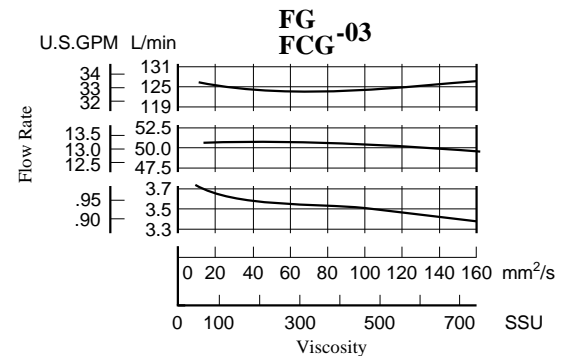
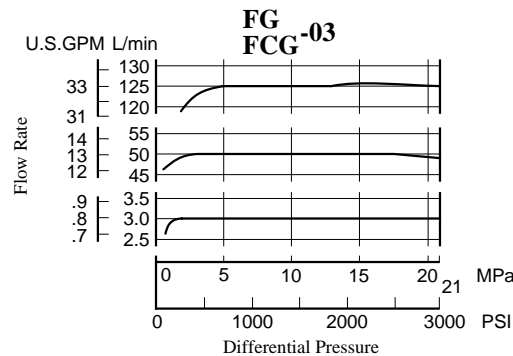
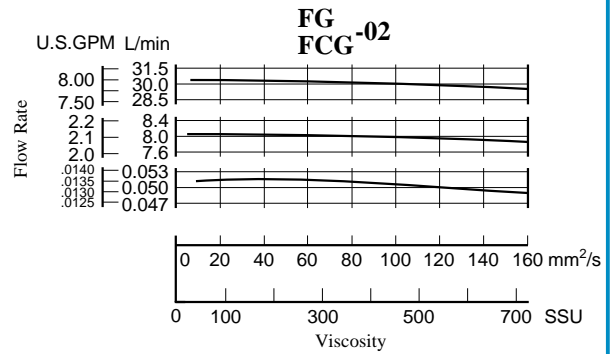
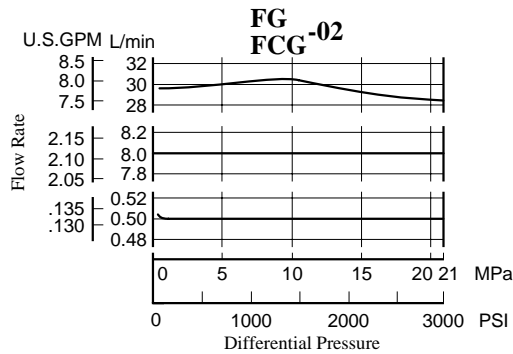
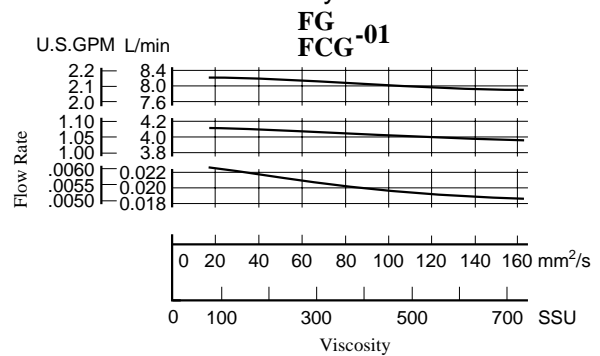
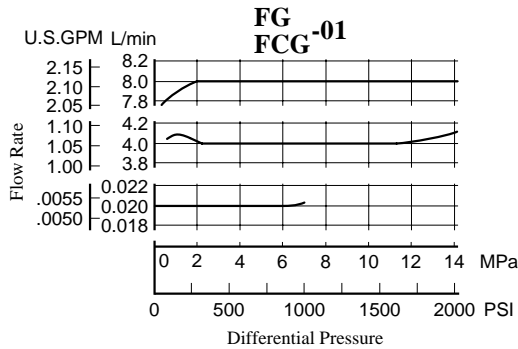

Metred Flow vs. Dial Position

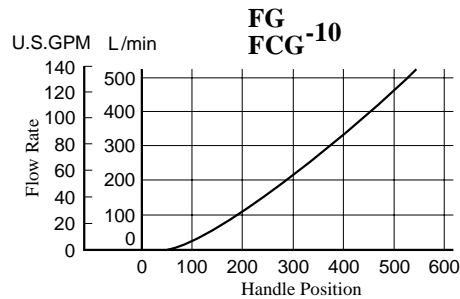
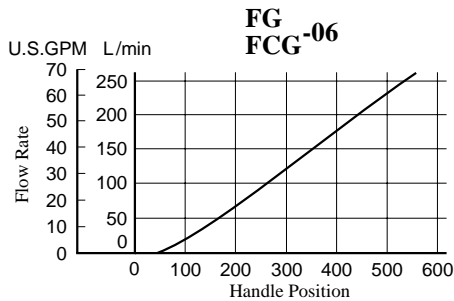
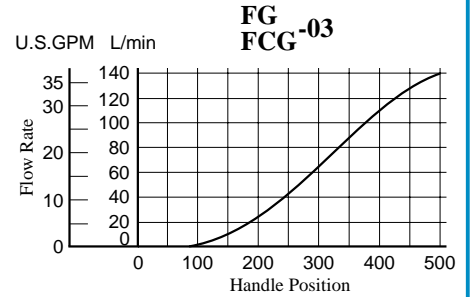
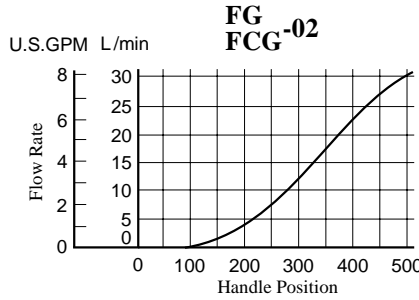
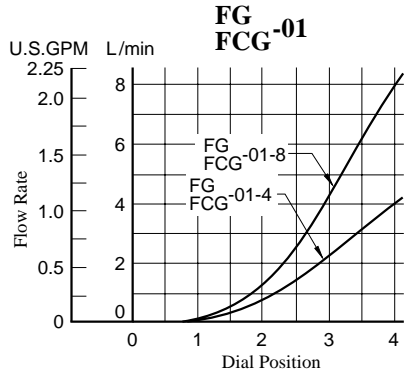

Min. Required Pressure Difference

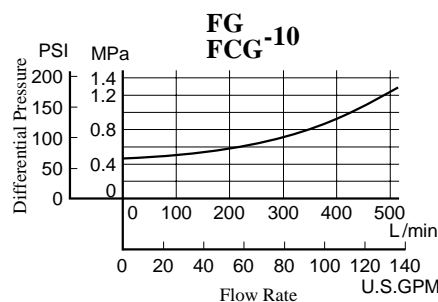
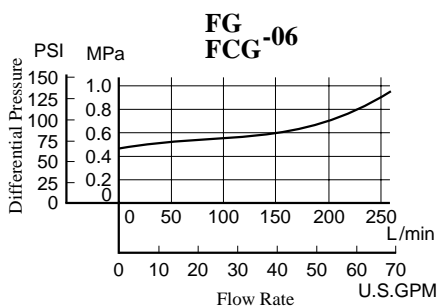
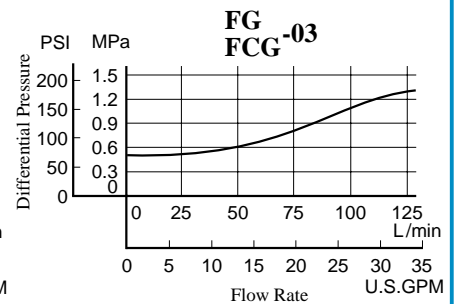
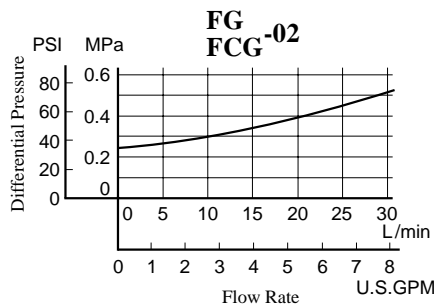
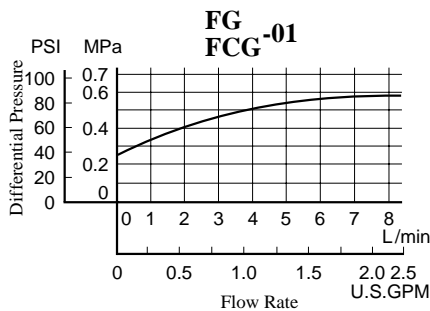

■ Pressure Drop for Reversed Free Flow

Hydraulic Fluid: Viscosity 35 mm²/s (164 SSU) , Specific Gravity 0.850

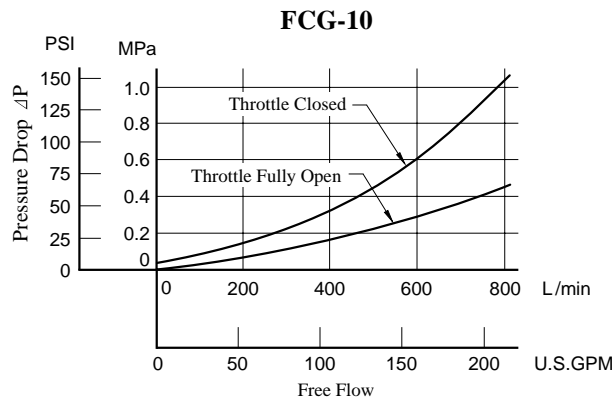
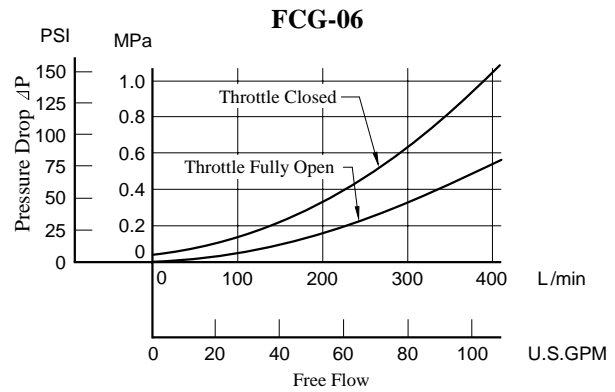
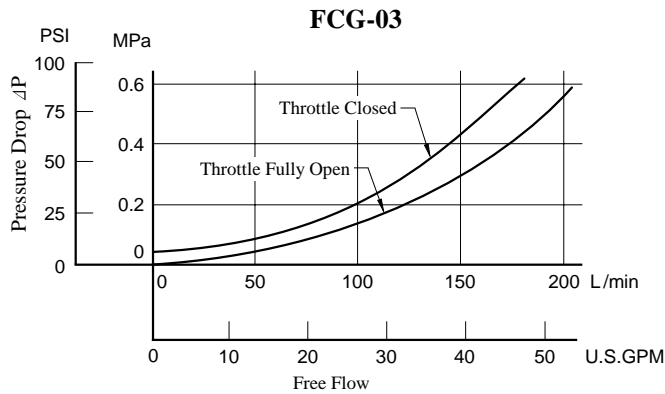
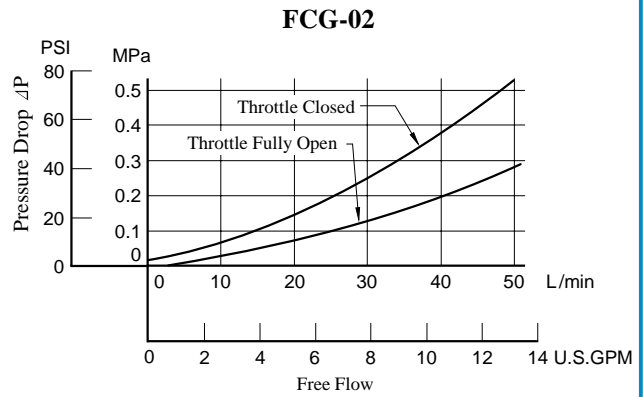
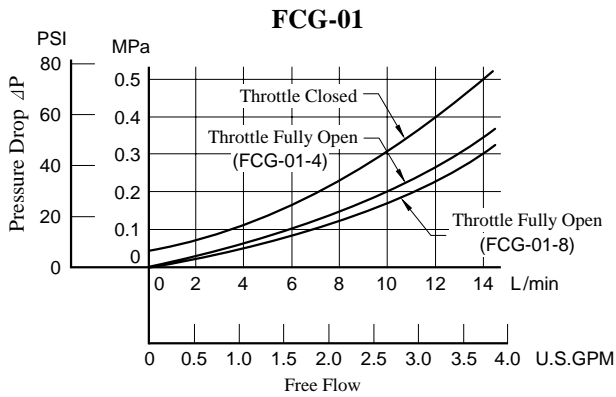

- For any other viscosity, multiply the factors in the table below.

Viscosity	mm ² /s	20	40	60	80	100
	SSU	98	186	278	371	464
Factor		0.87	1.03	1.14	1.23	1.30

- For any other specific gravity (G'), the pressure drop (ΔP') may be obtained from the formula below.

$$\Delta P' = \Delta P (G'/0.850)$$



FG
FCG -01-*-*-11/1190

CAUTION

When making replacement of seals, please do it carefully after reading through the relevant instructions in the Operator's Manual.

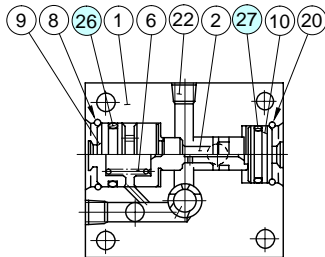

Section X-X
(FG-01 Type)

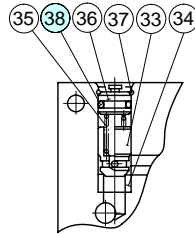

Section Y-Y
(FCG-01 Type)

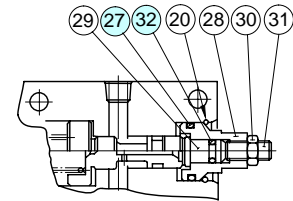

Section X-X
(FG/FCG-01-*-N Type)

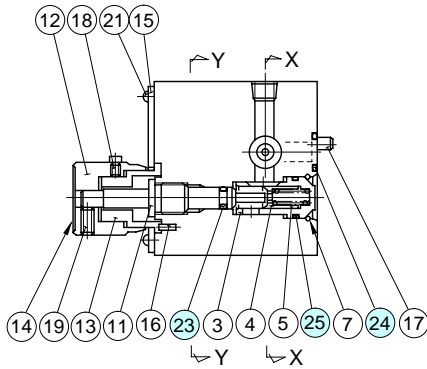

List of Seals

Item	Name of Parts	Part Numbers	Qty.
23	O-Ring	SO-NA-P4	1
24	O-Ring	SO-NB-P9	2
25	O-Ring	SO-NB-P10	1
26	O-Ring	SO-NB-P16	1
27	O-Ring	SO-NB-P14	1
32	O-Ring	SO-NA-P5	1
38	O-Ring	SO-NB-P7	1

Note: When ordering the seals, please specify the seal kit number from the table below.

List of Seal Kits

Model Numbers	Seal Kit Numbers
FG-01	KS-FG-01-11
FCG-01	KS-FCG-01-11

FG/FCG-02-30-*-*30/3090
FG/FCG-03-125-*-*30/3090

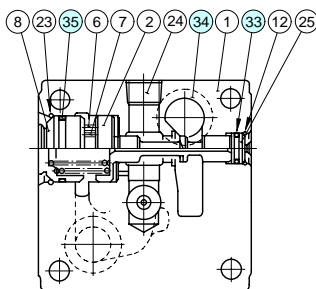

Section X-X
(FG-* Type)

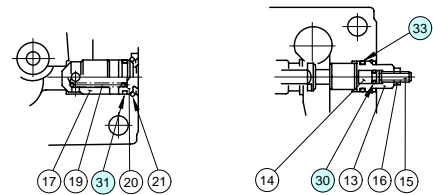
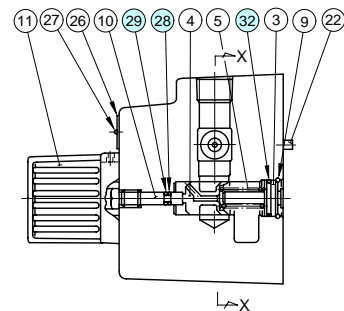

(FCG-* Type) (FG/FCG-*-N Type)
Section X-X

List of Seals

Item	Name of Parts	Part Numbers		Qty.
		FG FCG -02	FG FCG -03	
28	O-Ring	SO-NA-P4	SO-NA-P4	1
29	Back Up Ring	SO-BB-P4	SO-BB-P4	1
30	O-Ring	SO-NB-P5	SO-NB-P5	1
31	O-Ring	SO-NB-P10A	SO-NB-P16	1
32	O-Ring	SO-NB-P12	SO-NB-P18	1
33	O-Ring	SO-NB-P14	SO-NB-P14	1
34	O-Ring	SO-NB-P18	SO-NB-P28	2
35	O-Ring	SO-NB-G25	SO-NB-G35	1

Note: When ordering the seals, please specify the seal kit number from the table right.

List of Seal Kits

Model Numbers	Seal Kit Numbers
FG-02	KS-FG-02-30
FCG-02	KS-FCG-02-30
FG-03	KS-FG-03-30
FCG-03	KS-FCG-03-30

FG/FCG-06-250-*-30/3090
FG/FCG-10-500-*-30/3090

CAUTION

When making replacement of seals, please do it carefully after reading through the relevant instructions in the Operator's Manual.

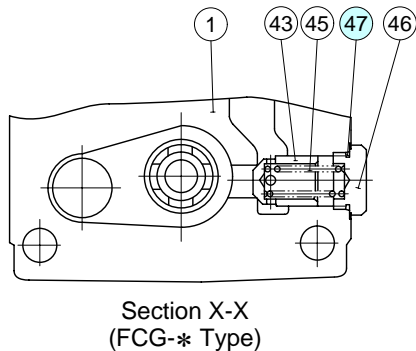
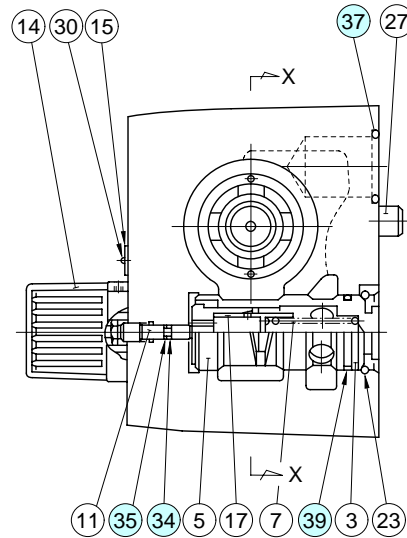
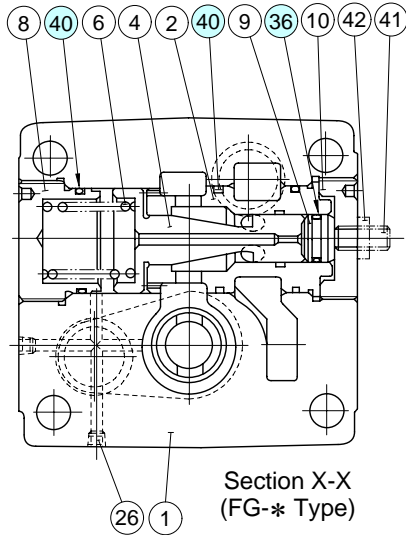

List of Seals

Item	Name of Parts	Part Numbers		Qty.
		FG FCG-06	FG FCG-10	
34	O-Ring	SO-NA-P4	SO-NA-P4	1
35	Back Up Ring	SO-BB-P4	SO-BB-P4	1
36	O-Ring	SO-NB-P21	SO-NB-P34	1
37	O-Ring	SO-NB-P32	SO-NB-P48	2
39	O-Ring	SO-NB-P34	SO-NB-P50	1
40	O-Ring	SO-NB-P50	SO-NB-G75	3
47	O-Ring	SO-NB-P24	SO-NB-P32	1

List of Seal Kits

Model Numbers	Seal Kit Numbers
FG-06	KS-FG-06-30
FCG-06	KS-FCG-06-30
FG-10	KS-FG-10-30
FCG-10	KS-FCG-10-30

Note) When ordering the seals, please specify the seal kit number from the table right.

D

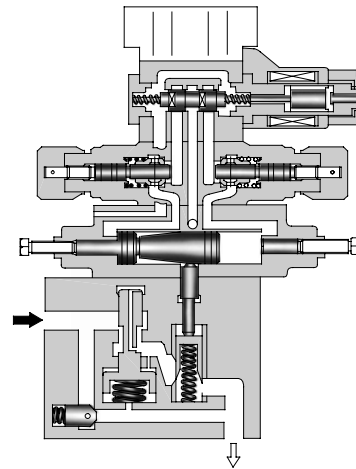
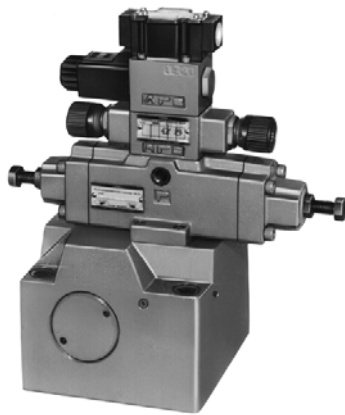

Specifications

Model Numbers	Max. Metred Flow Capacity L/min (U.S.GPM)	Min. Metred Flow Capacity L/min (U.S.GPM)	Max. Operating Pressure MPa (PSI)	Min. Pilot Pressure MPa (PSI)	Approx. Mass kg (lbs.)
FHG/FHCG-02-30-*-12*	30 (7.9)	0.05 (.013)	21 (3050)	1.5 (220)	13 (28.7)
FHG/FHCG-03-125-*-12*	125 (33)	0.2 (.053)			17 (37.5)
FHG/FHCG-06-250-*-12*	250 (66)	2 (.53)			32 (70.6)
FHG/FHCG-10-500-*-12*	500 (132)	4 (1.06)			61 (135)

Model Number Designation

F-	FHC	G	-02	-30	-N	-O	-A100	-N	-12	*
Special Seals	Series Number	Type of Mounting	Valve Size	Max. Metred Flow L/min (U.S.GPM)	Pressure Compensator Stroke Adj.	With No Pilot Valve*	Coil Type	Type of Electrical Connections	Design Number	Design Standards
F: Special Seals for Phosphate Ester Type Fluids (Omit if not required)	FH: Pilot Operated Flow Control Valves	G: Sub-plate Mounting	02	30 : 30 (7.9)	N: Applicable only for Pres. Compensator Stroke Adjustment (Option - Omit if not required)	O: Without Pilot Valve	AC: A100 A120 A200 A240 DC: D12 D24 D48 AC → DC: R100 R200	None: Terminal Box Type N: With Plug-in Connector (Din)	12	None: Japanese Std. "JIS"
			03	125 : 125 (33)					12	
	06		250 : 250 (66)	12					90: N.American Design Std.	
	10		500 : 500 (132)	12					80: European Design Std.	

* Either solenoid operated directional valve (DSG-01) or modular valve (MSW-01) can be used as a pilot valve.

If no pilot valve is required, there is no needs to specify the coil type and the electrical connection type of solenoid operated directional valve.

Graphic Symbols

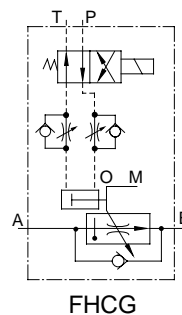
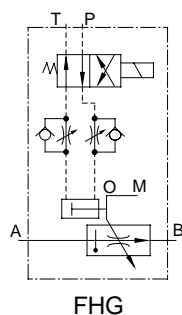

Solenoid Ratings

Electric Source	Coil Type	Frequency (Hz)	Voltage (V)		Current & Power at Rated Voltage		
			Source Rating	Serviceable Range	Inrush (A)*	Holding (A)	Power (W)
AC	A100	50	100	80 - 110	2.42	0.51	—
		60	100	90 - 120	2.14	0.37	
			110		2.35	0.44	
	A120	50	120	96 - 132	2.02	0.42	
		60		108 - 144	1.78	0.31	
	A200	50	200	160 - 220	1.21	0.25	
				60	180 - 240	1.07	
		220				1.18	
	A240	50	240	192 - 264	1.01	0.21	
		60		216 - 288	0.89	0.15	
DC (K Series)	D12	—	12	10.8 - 13.2	—	2.45	29
	D24		24	21.6 - 26.4		1.23	
	D48		48	43.2 - 52.8		0.61	
AC→DC Rectified	R100	50/60	100	90 - 110	—	0.33	29
	R200		200	180 - 220		0.16	

* Inrush current in the above table shows rms values at maximum stroke.

The coil type numbers in the shaded column are handled as optimal extras. In case these coils are required to be chosen, please confirm the time of delivery with us before ordering.

Attachment

Mounting Bolts

Valve Model Numbers	Socket Head Cap Screw		Qty.
	Japanese Std. "JIS" & European Design Std.	N. American Design Std.	
FHG/FHCG-02	M8 × 50 Lg.	5/16-18 UNC × 2 Lg.	4
FHG/FHCG-03	M10 × 75 Lg.	3/8-16 UNC × 3 Lg.	4
FHG/FHCG-06	M16 × 130 Lg.	5/8-11 UNC × 5 Lg.	4
FHG/FHCG-10	M20 × 160 Lg.	3/4-10 UNC × 6-1/2 Lg.	4

Option

Pres. compensator stroke adjustment

Can reduce jumping at the start of the actuator.

Sub-plate

Valve Model Numbers	Japanese Standard "JIS"		European Design Std.		N. American Design Std.		Approx. Mass kg (lbs.)
	Sub-plate Model No.	Thread Size	Sub-plate Model No.	Thread Size	Sub-plate Model No.	Thread Size	
FHG FHCG -02	FGM-02-20	Rc 1/4	FGM-02-2080	1/4 BSP.F	FGM-02-2090	1/4 NPT	2.3 (5.1)
	FGM-02X-20	Rc 3/8	FGM-02X-2080	3/8 BSP.F	FGM-02X-2090	3/8 NPT	2.3 (5.1)
	FGM-02Y-20	Rc 1/2	FGM-02Y-2080	1/2 BSP.F	FGM-02Y-2090	1/2 NPT	3.1 (6.8)
FHG FHCG -03	FGM-03-20	Rc 3/8	FGM-03-2080	3/8 BSP.F	FGM-03-2090	3/8 NPT	3.9 (8.6)
	FGM-03X-20	Rc 1/2	FGM-03X-2080	1/2 BSP.F	FGM-03X-2090	1/2 NPT	3.9 (8.6)
	FGM-03Y-20	Rc 3/4	FGM-03Y-2080	3/4 BSP.F	FGM-03Y-2090	3/4 NPT	5.7 (12.6)
	FGM-03Z-20	Rc 1	FGM-03Z-2080	1 BSP.F	FGM-03Z-2090	1 NPT	5.7 (12.6)
FHG FHCG -06	FGM-06X-20	Rc 1	FGM-06X-2080	1 BSP.F	FGM-06X-2090	1 NPT	12.5 (27.6)
	FGM-06Y-20	Rc 1-1/4	FGM-06Y-2080	1-1/4 BSP.F	FGM-06Y-2090	1-1/4 NPT	16 (35.3)
	FGM-06Z-20	Rc 1-1/2	FGM-06Z-2080	1-1/2 BSP.F	FGM-06Z-2090	1-1/2 NPT	16 (35.3)
FHG FHCG -10	FGM-10Y-20*	1-1/2, 2	FGM-10Y-20*	1-1/2, 2	FGM-10Y-2090*	1-1/2, 2	37 (81.6)

* Sub-plates are available. Specify the sub-plate model number from the table above. When sub-plates are not used, the mounting surface should have a good machined finish.

* Sub-plates are common with flow control valves. For dimensions, see pages 6 to 8.

* FGM-10Y is special type sub-plates to be used with pipe flange. When ordering FGM-10Y, specify the pipe flange kit in addition to FGM-10Y referring to F3 pipe flange kits Catalogue (No. Pub. EC-3001).

■ Instructions

● Control patterns and flow rate adjustment

- While the solenoid operated directional valve on (② shown below), the flow rate is at the level set by the maximum flow adjustment screw and the actuator operates at the maximum speed setting. Turning the adjustment screw clockwise causes the flow rate to decrease.
- While the solenoid operated directional valve off (④ shown below), the flow rate is set by the minimum flow adjustment screw and the actuator operates at the minimum speed setting. Turning the adjustment screw clockwise causes the flow rate to increase.
- When the solenoid operated directional valve is turned on (① shown below), the flow rate is shifted from minimum to maximum and the actuator speed is also shifted likewise. The switching time can be set by the pilot flow adjustment dial (for acceleration). Turning the adjustment dial clockwise causes the pilot flow rate to decrease.
- When the solenoid operated directional valve is turned off (③ shown below), the flow rate is shifted from maximum to minimum and the actuator speed is also shifted likewise. The switching time can be set by the pilot flow adjustment dial (for deceleration). Turning the adjustment dial clockwise causes the pilot flow rate to decrease.

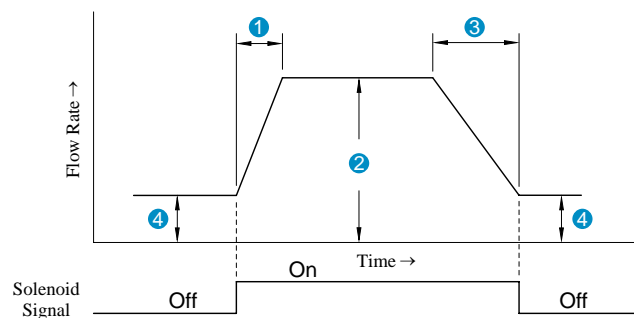

● Tightening of flow adjustment screws and dials

To adjust flow rates, slacken the lock nut or the dial setting screw. After adjustments, tighten the lock nut or the dial.

● Min. required pressure difference

The minimum differential pressure between inlet and outlet port is required to obtain the optimum pressure compensation. It varies according to the flow rate to be set. For details, please refer to the performance curves.

● Free flow

Check valve pressure drops vary with flow rates. If models with check valves are used, see free flow pressure drop characteristics.

● Line filter

To carry out flow adjustments by as small degree as 2 L/min (.53 U.S.GPM) or less, be sure to use a line filter of 10 μ m or finer and install it near the valve inlet.

■ **Metred Flow vs. Cylinders Stroke**

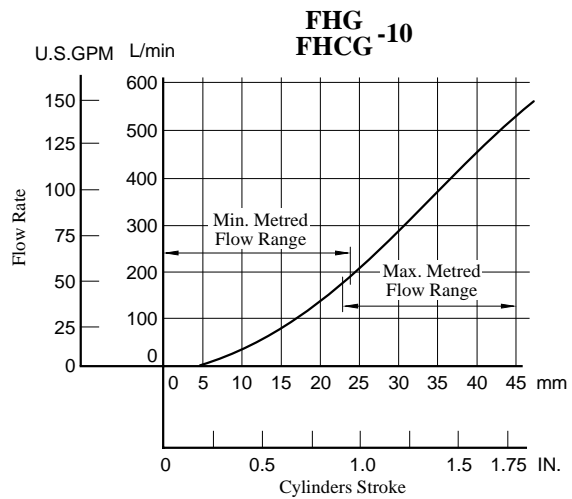
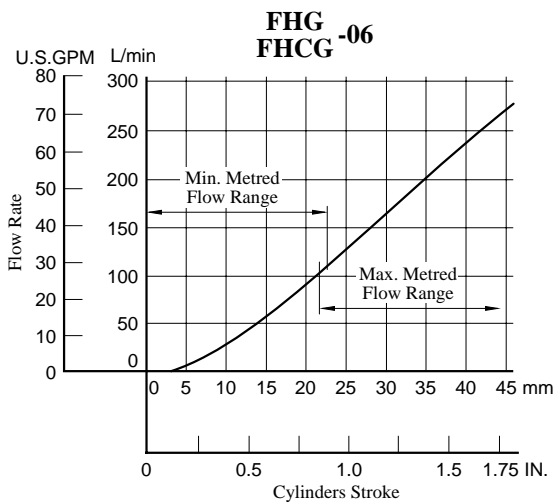
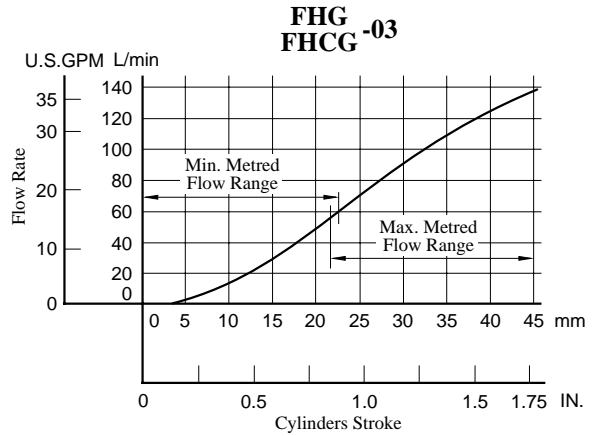
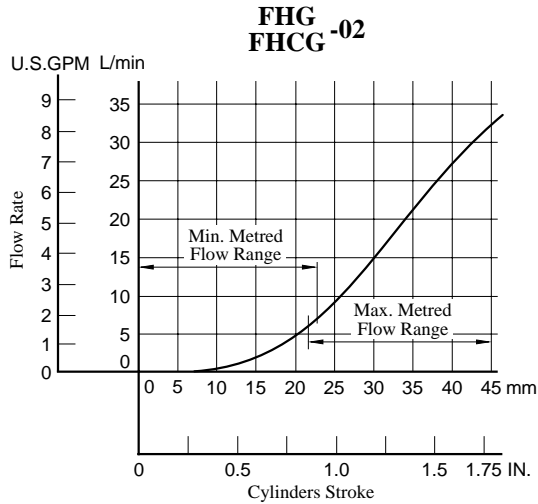

■ **Other Characteristics**

The following characteristics are the same as for flow control valves;

- Metred Flow vs. Differential Pressure
- Metred Flow vs. Viscosity
- Min. Required Pressure Difference
- Pressure Drop for Reversed Free Flow (only for models with check valves)

See pages 9 to 11. For reference, the corresponding model No. of the flow control valves are shown below.

Valve Model No.	Model No.
FHG FHCG -02	FG FCG -02
FHG FHCG -03	FG FCG -03
FHG FHCG -06	FG FCG -06
FHG FHCG -10	FG FCG -10



● Models with Plug-in Connector

FHG/FHCG-02-30-*-*-N-12/1280/1290

FHG/FHCG-03-125-*-*-N-12/1280/1290

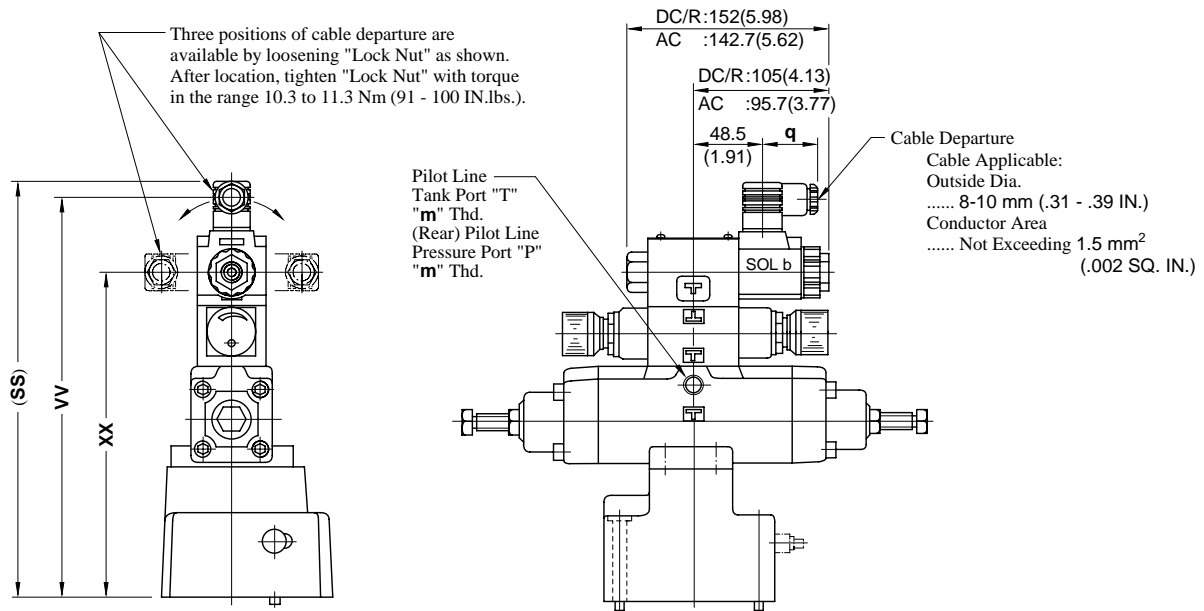

**DIMENSIONS IN
MILLIMETRES (INCHES)**

Model Numbers	Dimensions mm (Inches)				Remarks
	SS	VV	XX	q	
FHG/FHCG-02-30-*-*-A*-N	274 (10.79)	262 (10.31)	209 (8.23)	39 (1.54)	with AC Solenoid
FHG/FHCG-03-125-*-*-A*-N	303 (11.93)	291 (11.46)	238 (9.37)		
FHG/FHCG-02-30-*-*-D*-N	285 (11.22)	273 (10.75)	209 (8.23)	39 (1.54)	with DC Solenoid
FHG/FHCG-03-125-*-*-D*-N	314 (12.36)	302 (11.89)	238 (9.37)		
FHG/FHCG-02-30-*-*-R*-N	288 (11.34)	266.2 (10.48)	209 (8.23)	53 (2.09)	with AC→DC Solenoid
FHG/FHCG-03-125-*-*-R*-N	317 (12.48)	295.2 (11.62)	238 (9.37)		

Model Numbers	Thread Size		
	Japanese Std. "JIS" Design 12	European Design Std. Design 1280	N.American Design Std. Design 1290
	"n" Thd.	"n" Thd.	"n" Thd.
FHG/FHCG-02-30-*-*-N	Rc 1/4	1/4 BSP.F	1/4 NPT
FHG/FHCG-03-125-*-*-N			

● For other dimensions, refer to "Terminal Box Type".



● Terminal Box Type

FHG/FHCG-06-250-*-12/1290
FHG/FHCG-10-500-*-12/1290

**DIMENSIONS IN
MILLIMETRES (INCHES)**

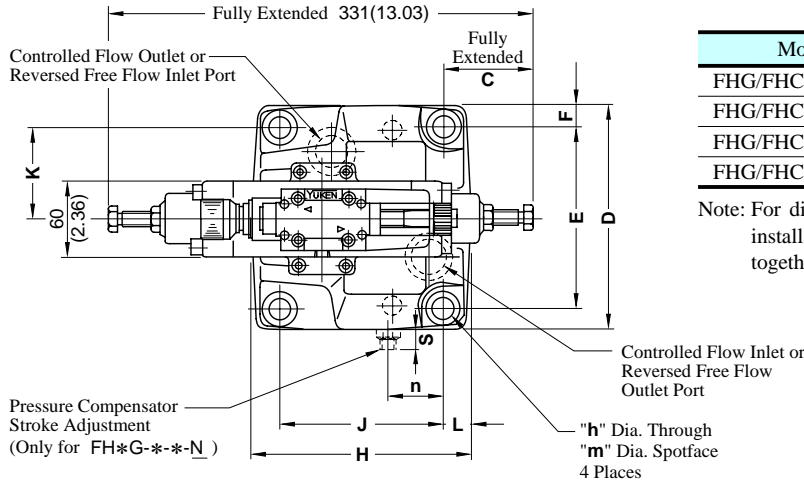

Model Numbers	q	r
FHG/FHCG-06-250-*-12	Rc 1/4	G 1/2
FHG/FHCG-06-250-*-1290	1/4 NPT	1/2 NPT
FHG/FHCG-10-500-*-12	Rc 1/4	G 1/2
FHG/FHCG-10-500-*-1290	1/4 NPT	1/2 NPT

Note: For dimensions of the valve mounting surface, see the installation drawing (P. 7 and 8) of the sub-plate used together.

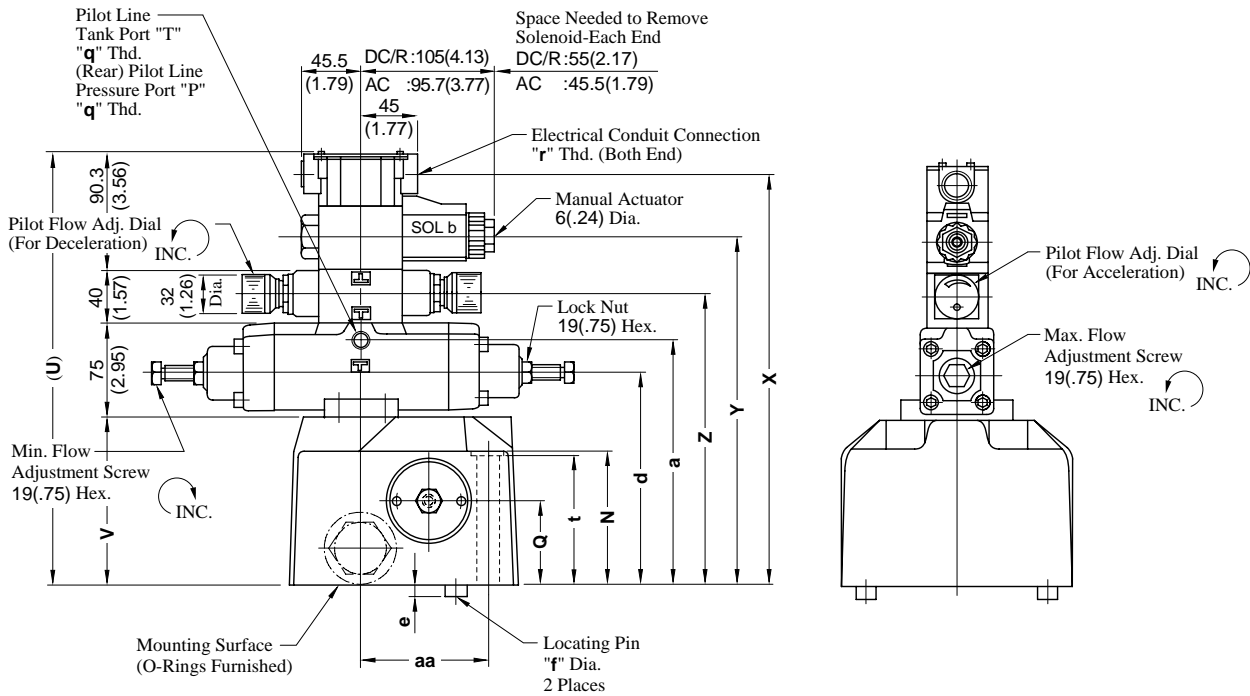

Model Numbers	Dimensions mm (Inches)															
	C	D	E	F	H	J	K	L	N	Q	S	U	V	X	Y	Z
FHG-06 FHCG-06	66.5 (2.62)	180 (7.09)	146.1 (5.75)	17 (.67)	174 (6.85)	133.4 (5.25)	73.1 (2.88)	20.3 (.80)	105 (4.13)	65 (2.56)	18 (.71)	335.3 (13.20)	130 (5.12)	317 (12.48)	270 (10.63)	223 (8.78)
FHG-10 FHCG-10	21 (.83)	244 (9.61)	196.9 (7.75)	23.5 (.93)	228 (8.98)	177.8 (7.00)	98.5 (3.88)	25.1 (.99)	137 (5.39)	85 (3.35)	23 (.91)	365.3 (14.38)	160 (6.30)	347 (13.66)	300 (11.81)	253 (9.96)

Model Numbers	Dimensions mm (Inches)								
	a	d	e	f	h	m	n	t	aa
FHG-06 FHCG-06	190 (7.48)	165 (6.50)	7 (.28)	16 (.63)	17.5 (.69)	26 (1.02)	44 (1.73)	103 (4.06)	99 (3.90)
FHG-10 FHCG-10	220 (8.66)	195 (7.68)	10 (.39)	18 (.71)	21.5 (.85)	32 (1.26)	61 (2.40)	135 (5.31)	144.5 (5.69)

● Models with Plug-in Connector

FHG/FHCG-06-250-*-N-12/1280/1290

FHG/FHCG-10-500-*-N-12/1280/1290

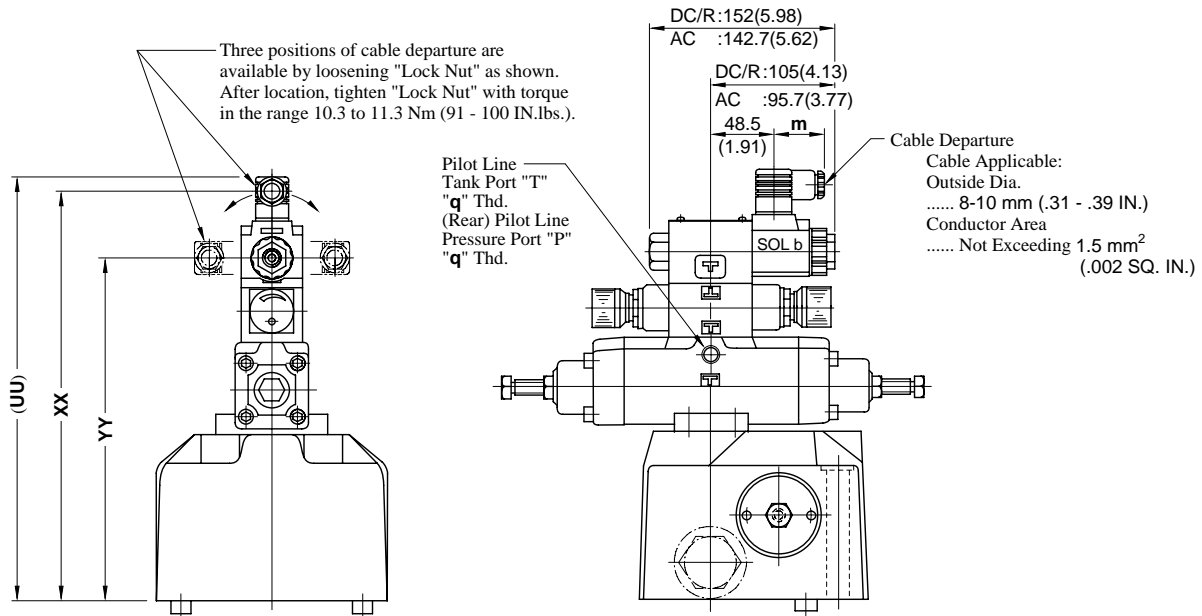

**DIMENSIONS IN
MILLIMETRES (INCHES)**

Model Numbers	Dimensions mm (Inches)				Remarks
	UU	XX	YY	m	
FHG/FHCG-06-250-*-A*-N	335 (13.19)	323 (12.72)	270 (10.63)	39 (1.54)	with AC Solenoid
FHG/FHCG-10-500-*-A*-N	365 (14.37)	353 (13.90)	300 (11.81)		
FHG/FHCG-06-250-*-D*-N	346 (13.62)	334 (13.15)	270 (10.63)	39 (1.54)	with DC Solenoid
FHG/FHCG-10-500-*-D*-N	376 (14.80)	364 (14.33)	300 (11.81)		
FHG/FHCG-06-250-*-R*-N	349 (13.74)	327.2 (12.88)	270 (10.63)	53 (2.09)	with AC→DC Solenoid
FHG/FHCG-10-500-*-R*-N	379 (14.92)	357.2 (14.06)	300 (11.81)		

Model Numbers	Thread Size		
	Japanese Std. "JIS" Design 12	European Design Std. Design 1280	N.American Design Std. Design 1290
	"q" Thd.	"q" Thd.	"q" Thd.
FHG/FHCG-06-250-*-N	Rc 1/4	1/4 BSP.F	1/4 NPT
FHG/FHCG-10-500-*-N			

● For other dimensions, refer to "Terminal Box Type".

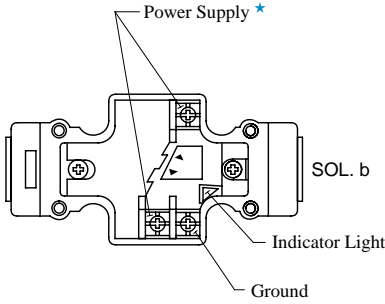
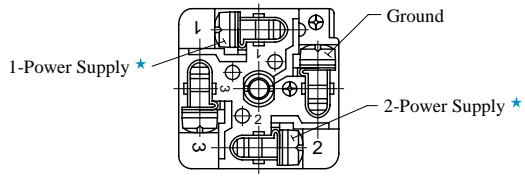

Details of Receptacle

Terminal Box Type	Plug-in Connector Type
	

★ With DC solenoids, polarity is no question.

⚠ DANGER

- Do not perform wiring while the power is on. Doing so may result in electric shock, burns or death.
- Make the wiring properly. Improper wiring will cause an irregular movement of the machine, resulting in a grave accident.

Electrical Circuit

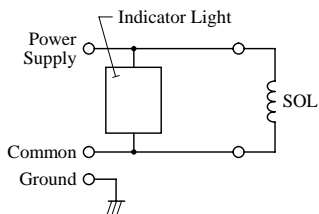
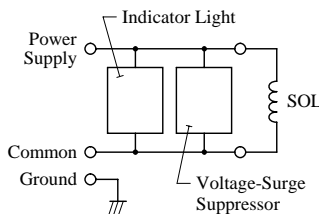
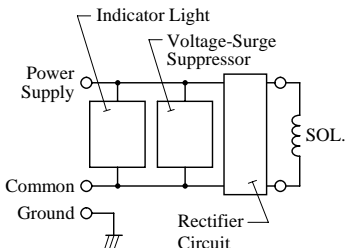
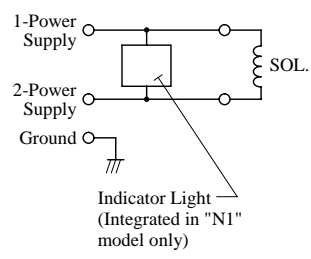
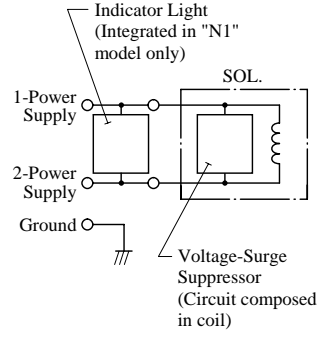
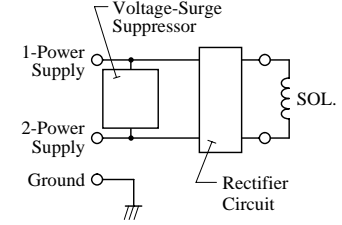
Type of Electrical Conduit Connection	Electric Source		
	AC	DC	AC→DC Rectified
Terminal Box Type			
Plug-in Connector Type			

⚠ CAUTION

When making replacement of seals, please do it carefully after reading through the relevant instructions in the Operator's Manual.

● Terminal Box Type

FHG/FHCG-02-30-*-*/-12/1290
FHG/FHCG-03-125-*-*/-12/1290

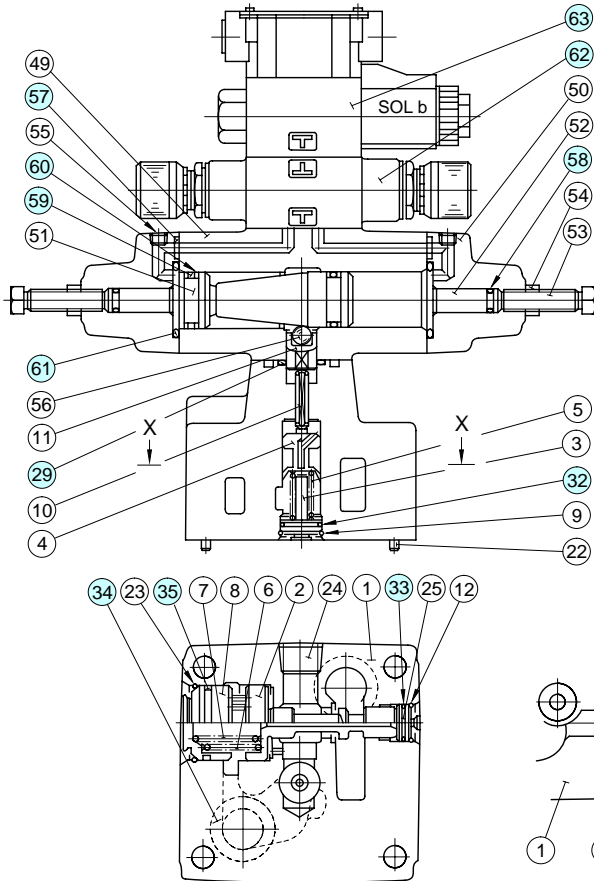

(FHG-* Type)

● Models with Plug-in Connector

FHG/FHCG-02-30-*-*/-N-12/1280/1290
FHG/FHCG-03-125-*-*/-N-12/1280/1290

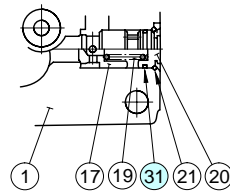
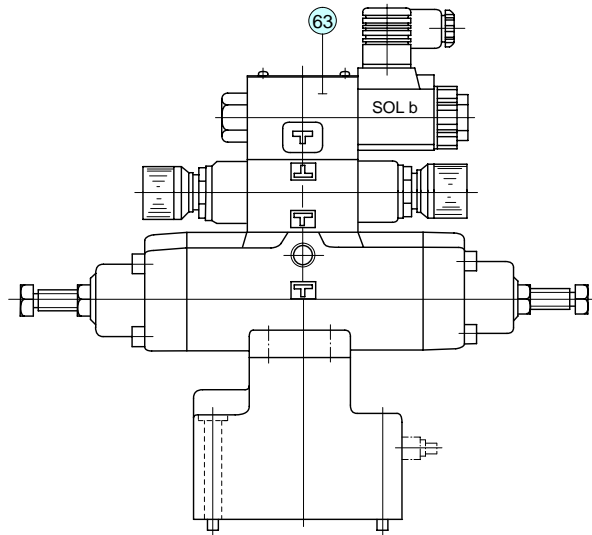

(FHCG-* Type)
Section X-X

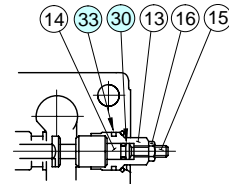

(FHG
FHCG -*-*-N Type)

● List of Seals

Item	Name of Parts	Part Numbers		Qty.
		FHG FHCG -02	FHG FHCG -03	
29	O-Ring	SO-NB-P20	SO-NB-P20	1
30	O-Ring	SO-NB-P5	SO-NB-P5	1
31	O-Ring	SO-NB-P10A	SO-NB-P16	1
32	O-Ring	SO-NB-P12	SO-NB-P18	1
33	O-Ring	SO-NB-P14	SO-NB-P14	1
34	O-Ring	SO-NB-P18	SO-NB-P28	2
35	O-Ring	SO-NB-G25	SO-NB-G35	1
57	O-Ring	SO-NB-P9	SO-NB-P9	2
58	O-Ring	SO-NB-P10A	SO-NB-P10A	2
59	O-Ring	SO-NA-P26	SO-NA-P26	2
60	Back Up Ring	SO-BB-P26	SO-BB-P26	4
61	O-Ring	SO-NB-P38	SO-NB-P38	2

Note) When ordering the seals, please specify the seal kit number from the table right. In addition to the above seals, seals for pilot valves are included in the seal kit.

● Pilot Valves

See page 25 for the pilot valve model numbers to be used.

● List of Seal Kits

Model Numbers	Seal Kit Numbers
FHG-02	KS-FHG-02-12
FHCG-02	KS-FHCG-02-12
FHG-03	KS-FHG-03-12
FHCG-03	KS-FHCG-03-12

⚠ CAUTION

When making replacement of seals, please do it carefully after reading through the relevant instructions in the Operator's Manual.

● Terminal Box Type

FHG/FHCG-06-250-*-*/12/1290
FHG/FHCG-10-500-*-*/12/1290

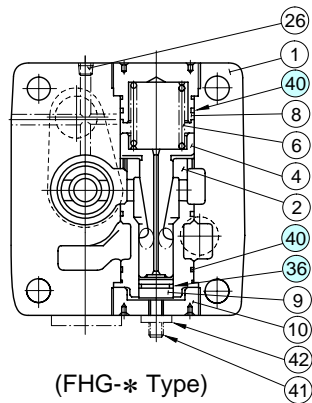
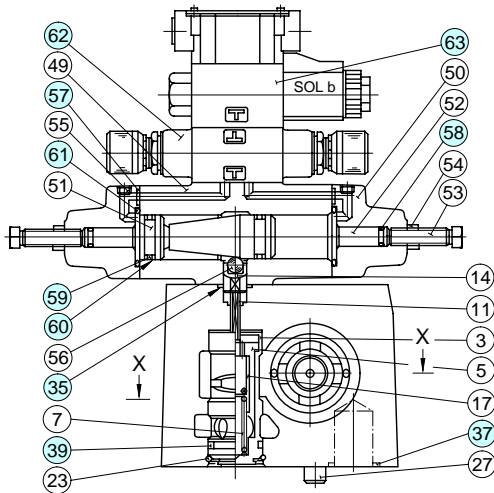

(FHG-* Type)
Section X-X

● Models with Plug-in Connector

FHG/FHCG-06-250-*-*/N-12/1280/1290
FHG/FHCG-10-500-*-*/N-12/1280/1290

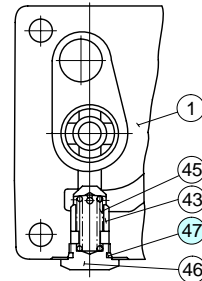
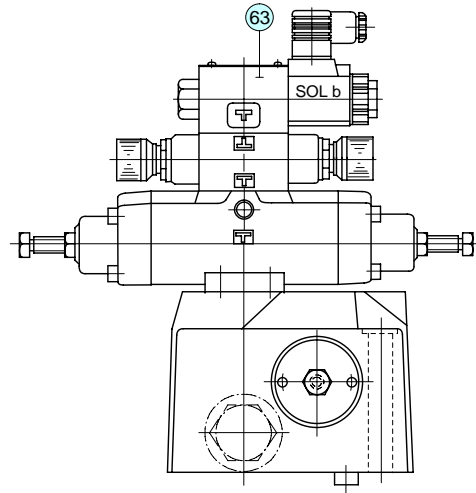

(FHCG-* Type)
Section X-X

● List of Seals

Item	Name of Parts	Part Numbers		Qty.
		FHG FHCG-06	FHG FHCG-10	
35	O-Ring	SO-NB-P20	SO-NB-P20	1
36	O-Ring	SO-NB-P21	SO-NB-P34	1
37	O-Ring	SO-NB-P32	SO-NB-P48	2
39	O-Ring	SO-NB-P34	SO-NB-P50	1
40	O-Ring	SO-NB-P50	SO-NB-G75	3
47	O-Ring	SO-NB-P24	SO-NB-P32	1
57	O-Ring	SO-NB-P9	SO-NB-P9	2
58	O-Ring	SO-NB-P10A	SO-NB-P10A	2
59	O-Ring	SO-NA-P26	SO-NA-P26	2
60	Back Up Ring	SO-BB-P26	SO-BB-P26	4
61	O-Ring	SO-NB-P38	SO-NB-P38	2

Note) When ordering the seals, please specify the seal kit number from the table right. In addition to the above seals, seals for pilot valves are included in the seal kit.

● Pilot Valves

See page 25 for the pilot valve model numbers to be used.

● List of Seal Kits

Model Numbers	Seal Kit Numbers
FHG-06	KS-FHG-06-12
FHCG-06	KS-FHCG-06-12
FHG-10	KS-FHG-10-12
FHCG-10	KS-FHCG-10-12

● List of Pilot Valves

Type of Electrical Conduit Connections	Valve Model Numbers	Pilot Valve Model Numbers		Remarks
		Item No.62 Throttle and Check Modular Valves	Item No.63 Solenoid Operated Directional Valves	
Terminal Box Type	FHG/FHCG-02- 30-* -★ -12 FHG/FHCG-03-125-* -★ -12 FHG/FHCG-06-250-* -★ -12 FHG/FHCG-10-500-* -★ -12	MSW-01-X-50	DSG-01-2B2-★ -60	Japanese Std. "JIS"
	FHG/FHCG-02- 30-* -★ -1290 FHG/FHCG-03-125-* -★ -1290 FHG/FHCG-06-250-* -★ -1290 FHG/FHCG-10-500-* -★ -1290	MSW-01-X-5090	DSG-01-2B2-★ -6090	N. American Design Std.
Plug-in Connector Type	FHG/FHCG-02- 30-* -★ -N-12 FHG/FHCG-03-125-* -★ -N-12 FHG/FHCG-06-250-* -★ -N-12 FHG/FHCG-10-500-* -★ -N-12	MSW-01-X-50	DSG-01-2B2-★ -N-60	Japanese Std. "JIS"
	FHG/FHCG-02- 30-* -★ -N-1280 FHG/FHCG-03-125-* -★ -N-1280 FHG/FHCG-06-250-* -★ -N-1280 FHG/FHCG-10-500-* -★ -N-1280	MSW-01-X-50	DSG-01-2B2-★ -N-60	European Design Std.
	FHG/FHCG-02- 30-* -★ -N-1290 FHG/FHCG-03-125-* -★ -N-1290 FHG/FHCG-06-250-* -★ -N-1290 FHG/FHCG-10-500-* -★ -N-1290	MSW-01-X-5090	DSG-01-2B2-★ -N-6090	N. American Design Std.

- Note: 1. Fill a coil type (a symbol representing current/voltage) in section marked ★.
 2. For the detail of the MSW-01 valve O-rings, see the Catalogue No. Pub. EC-1402.
 3. For the detail of the DSG-01 valve O-rings, see the Catalogue No. Pub. EC-0402.





FLOW CONTROL AND RELIEF VALVES FBG-03/06/10 (3/8, 3/4, 1-1/4) Sub-plate Mounting

FLOW
CONTROLS

Model Number Designation / Specifications

Up to 25 MPa (3630 PSI), 500 L/min (132 U.S.GPM)

These valves are flow control valves having the functions of metre-in type flow control and pressure control. Inlet pressure is always maintained 0.6 MPa (87 PSI) higher than the load pressure. In a conventional flow control method, power consumption is wasteful since the pump pressure goes up to the preset system pressure regardless of the load pressure. While, the power saving valves control the pump pressure by maintaining a differential pressure as little as 0.6 MPa (87 PSI) against the load pressure, thereby, the power can be remarkably saved. Moreover, with lthe temperature compensator, a stable flow control can be made regardless of oil temperature. Setting and repeat setting of flow can be made easily with an adjustment knob having digital scales.

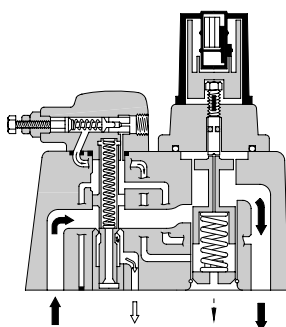

Graphic Symbol

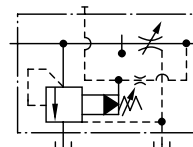

Specifications

Description	Model Numbers	FBG-03-125	FBG-06-250	FBG-10-500
Max. Operating Pressure	MPa (PSI)	25 (3630)	25 (3630)	25 (3630)
	L/min (U.S.GPM)	125 (33)	250 (66)	500 (132)
Metred Flow Range	L/min (U.S.GPM)	1-125 (.26-33)	3-250 (.79-66)	5-500 (1.3-132)
Pressure Adjustment Range	MPa (PSI)	★-25 (★-3630) *	★-25 (★-3630) *	★-25 (★-3630) *
Min. Pressure Difference Required between Inlet and Outlet Ports	MPa (PSI)	0.6 (87)	0.7 (102)	0.9 (131)
Pilot Drain Flow	L/min (U.S.GPM)	1.5 (.40)	2.4 (.63)	3.5 (.92)
Max. Drain Line and Tank Line Back Pressure	MPa (PSI)	0.5 (73)	0.5 (73)	0.5 (73)
Approx. Mass	kg (lbs.)	13.3 (29.3)	27.3 (60.2)	57.3 (126)

* See the "Min. Adjustment Pressure" for the item marked ★ .

Model Number Designation

F-	FB	G	-03	-125	-10	*
Special Seals	Series Number	Type of Mounting	Valve Size	Max. Metred Flow L/min (U.S.GPM)	Design Number	Design Standards
F: Special Seals for Phosphate Ester Type Fluids (Omit if not required)	FB: Flow Control and Relief Valves	G: Sub-plate Mounting	03	125 : 125 (33)	10	Refer to ★ 1
			06	250 : 250 (66)	10	
			10	500 : 500 (132)	10	

★ 1. Design Standards :

- None. Japanese Standard "JIS" and European Design Standard
- 90 N. American Design Standard



Hydraulic Fluids

Fluid Types

Any type of hydraulic fluids listed in the table below can be used.

Petroleum base oils	Use fluids equivalent to ISO VG32 or VG46.
Synthetic fluids	Use phosphate ester or polyol ester fluid. When phosphate ester fluid is used, prefix "F-" to the model number because the special seals (fluororubber) are required to be used.
Water containing fluids	Use water-glycol fluid.

Note: For use with hydraulic fluids other than those listed above, please consult your Yuken representatives in advance.

Recommended Viscosity and Oil Temperatures

Viscosity ranging between 15 - 400 mm²/s (77 - 1800 SSU).

Oil temperatures between -15/+70°C (5 - 158°F).

Use hydraulic fluids which satisfy the recommended viscosity and oil temperatures given above.

Control of Contamination

Due caution must be paid to maintaining control over contamination of the hydraulic fluids which may otherwise lead to breakdowns and shorten the life of the valves. Please maintain the degree of contamination within NAS 1638-Grade 12. Use 25 µm or finer line filter.

Instructions

Flow adjustment

Loosen the locking screw and turn the flow adjustment handle clockwise to increase, and anti-clockwise to decrease. Open condition is indicated in digital-scale in built-in revolution indicator (Refer to characteristics of "Metred flow vs. Dial Position").

After flow adjustments, tighten the locking screw.

Pressure adjustment

To adjust the pressure, loosen the lock nut and turn the pressure adjustment screw slowly clockwise to increase pressures or anti-clockwise to decrease pressure. After adjustments, do not forget to tighten the lock nut.

Drain port back pressure

Note that any drain port back pressure is added to the minimum pressure.

Connect the drain port, preferably with its back pressure minimized, directly to the oil tank.

Relief valve throughput

When the relief valve throughput is small with pressure under control, the pressure setting may become unstable.

Thus, hold the rate above 10 L/min (2.6 U.S.GPM) for nominal valve size 03 and 06 or above 15 L/min (4 U.S. GPM) for nominal valve size 10.

Line filter

In case of controlling flow rate of less than 2 L/min (.53 U.S.GPM), be sure to use a line filter of 10µm or finer at the valve inlet.

Attachment

Mounting Bolts

Valve Model Numbers	Socket Head Cap Screw			Qty.
	Japanese Std. "JIS" and European Design Std.	N. American Design Std.		
FBG-03	M10 × 100 Lg.	3/8-16 UNC × 4 Lg.		4
FBG-06	M16 × 130 Lg.	5/8-11 UNC × 5 Lg.		4
FBG-10	M20 × 130 Lg.	3/4-10 UNC × 5 Lg.		4

Sub-plate

Valve Model Numbers	Japanese Standard "JIS"		European Design Standard		N. American Standard		Approx. Mass kg (lbs.)
	Sub-plate Model No.	Thread Size	Sub-plate Model No.	Thread Size	Sub-plate Model No.	Thread Size	
FBG-03	EFBGM-03Y-10	Rc 3/4	EFBGM-03Y-1080	3/4 BSP.F	EFBGM-03Y-1090	3/4 NPT	6 (13.2)
	EFBGM-03Z-10	Rc 1	EFBGM-03Z-1080	1 BSP.F	EFBGM-03Z-1090	1 NPT	6 (13.2)
FBG-06	EFBGM-06X-10	Rc 1	EFBGM-06X-1080	1 BSP.F	EFBGM-06X-1090	1 NPT	12.5 (27.6)
	EFBGM-06Y-10	Rc 1-1/4	EFBGM-06Y-1080	1-1/4 BSP.F	EFBGM-06Y-1090	1-1/4 NPT	16 (35.3)
FBG-10	EFBGM-10Y-10	1-1/2, 2	EFBGM-10Y-1080	1-1/2, 2	EFBGM-10Y-1090	1-1/2, 2	37 (81.6)

Sub-plates are available. Specify the sub-plate model number from the table above. When sub-plates are not used, the mounting surface should have a good machined finish.

EFBGM-10Y is special type sub-plates to be used with pipe flange. When ordering EFBGM-10Y, specify pipe flange in addition to EFBGM-10Y referring to F3 pipe flange catalogue (No. Pub. EC-3001).

FBG-03-125-10/1090

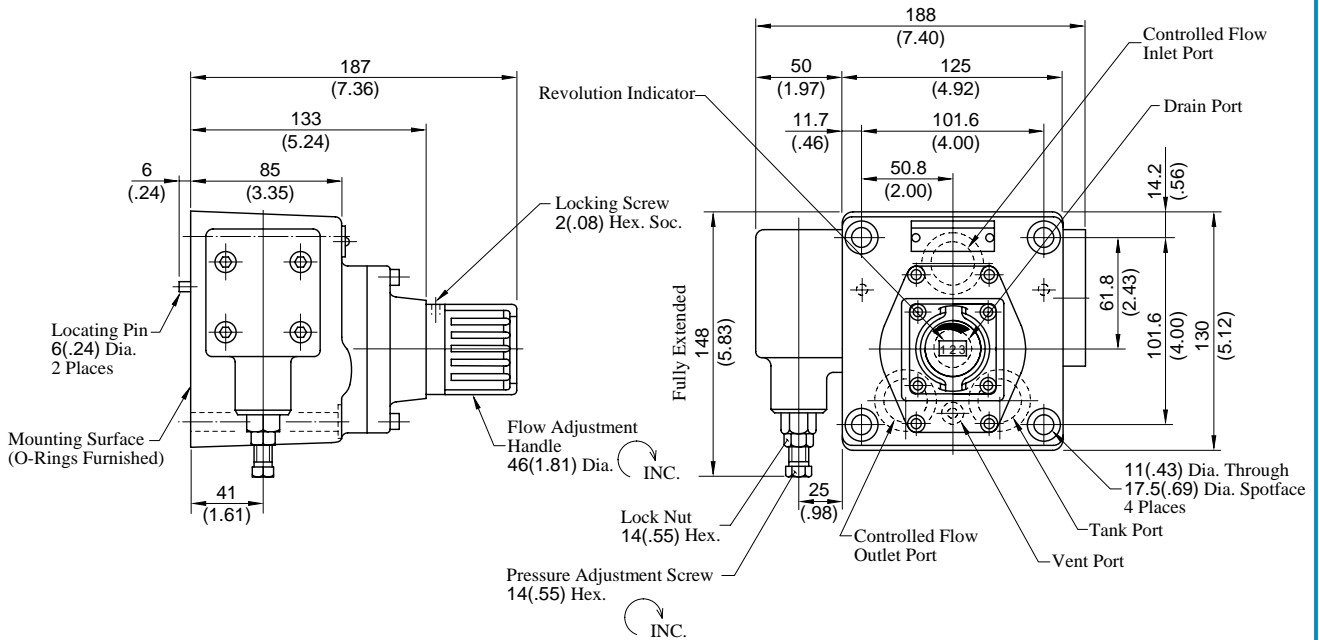

**DIMENSIONS IN
MILLIMETRES (INCHES)**

Sub-plate

EFBGM-03Y/03Z-10/1080/1090

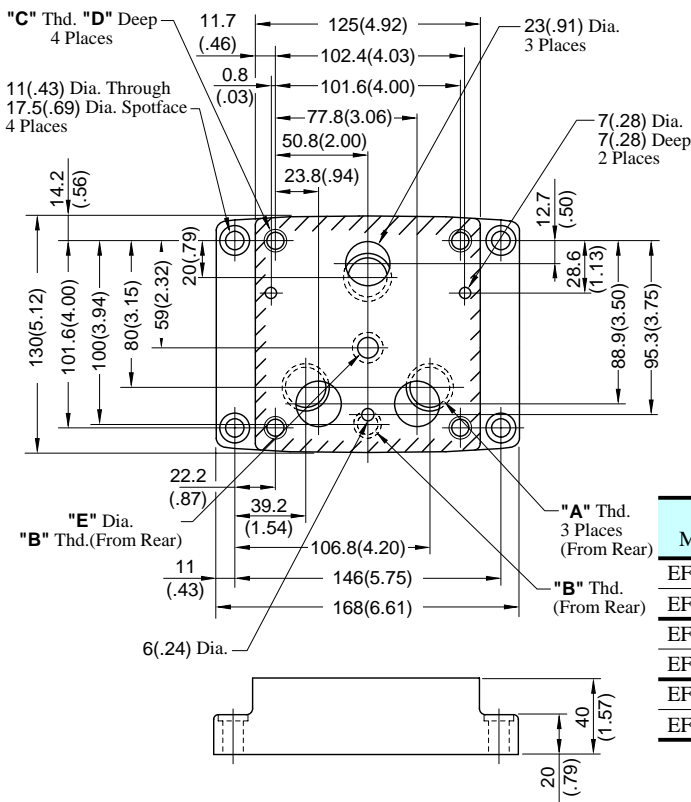

Sub-plate Model Numbers	Thread Size			D	E
	"A" Thd.	"B" Thd.	"C" Thd.		
EFBGM-03Y-10	Rc 3/4	Rc 1/4	M10	18 (.71)	11 (.43)
EFBGM-03Z-10	Rc 1				11.7 (.46)
EFBGM-03Y-1080	3/4 BSP.F	1/4 BSP.F			11 (.43)
EFBGM-03Z-1080	1 BSP.F				11.7 (.46)
EFBGM-03Y-1090	3/4 NPT	1/4 NPT	3/8-16 UNC	21 (.83)	11 (.43)
EFBGM-03Z-1090	1 NPT				11 (.43)

FBG-06-250-10/1090

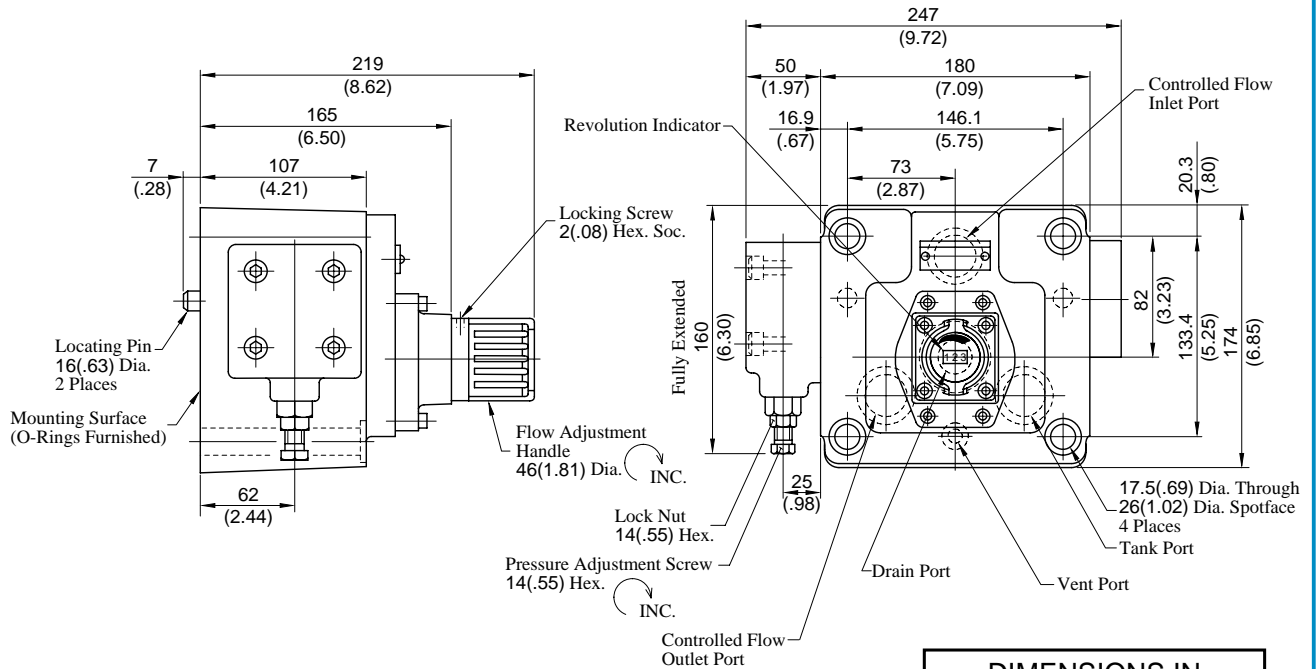

**DIMENSIONS IN
MILLIMETRES (INCHES)**

Sub-plate

EFBGM-06X/06Y-10/1080/1090

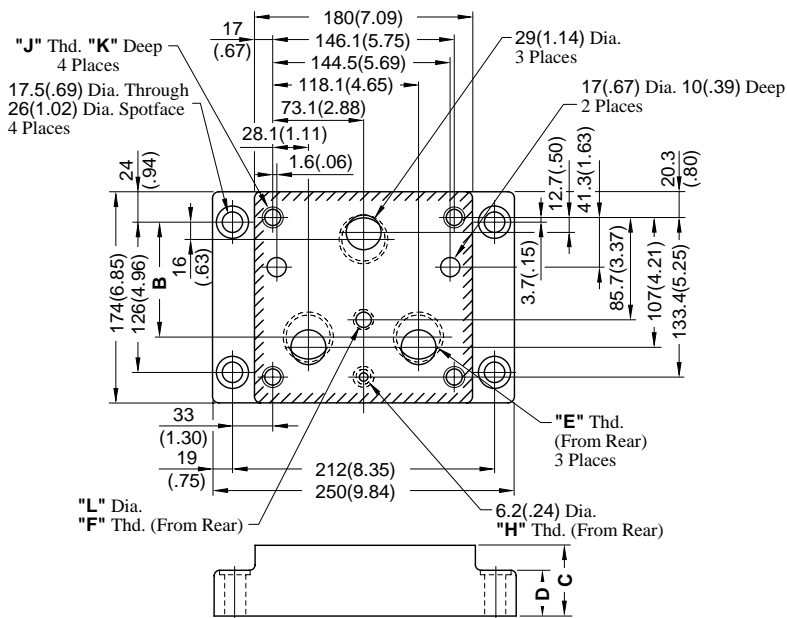

Sub-plate Model No.	Dimensions mm (IN.)		
	B	C	D
EFBGM-06X	103.3 (4.07)	45 (1.77)	35 (1.38)
EFBGM-06Y	95 (3.74)	60 (2.36)	40 (1.57)

Sub-plate Model No.	Thread Size				mm (IN.)	
	"E" Thd.	"F" Thd.	"H" Thd.	"J" Thd.	K	L
EFBGM-06X-10	Rc 1	Rc 3/8	Rc 1/4	M 16	30 (1.18)	14 (.55)
EFBGM-06Y-10	Rc 1-1/4					
EFBGM-06X-1080	1 BSP.F	3/8 BSP.F	1/4 BSP.F	M 16	30 (1.18)	15.2 (.60)
EFBGM-06Y-1080	1-1/4 BSP.F					
EFBGM-06X-1090	1 NPT	3/8 NPT	1/4 NPT	5/8-11 UNC	35 (1.38)	14 (.55)
EFBGM-06Y-1090	1-1/4 NPT					

■ Min. Adjustment Pressure

FBG-03

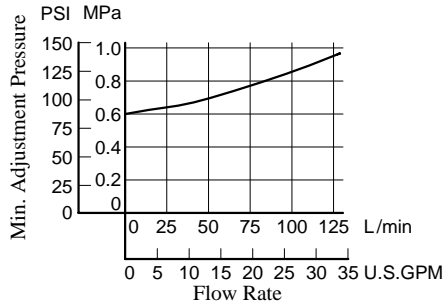

FBG-06

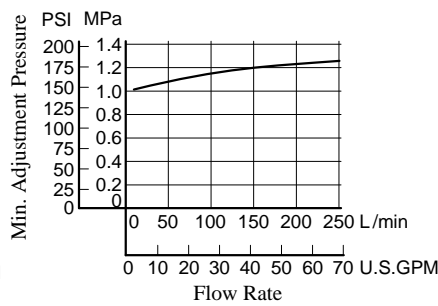

FBG-10

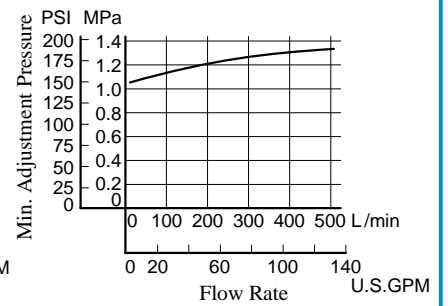

■ Load Pressure vs. Metred Flow

FBG-03

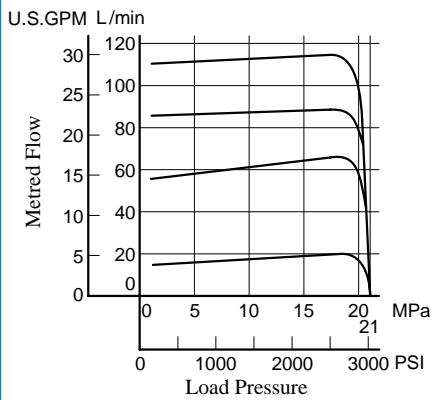

FBG-06

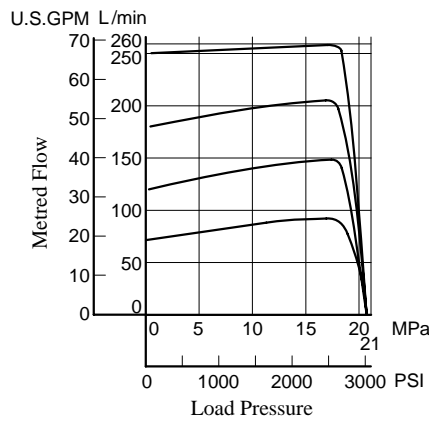

FBG-10

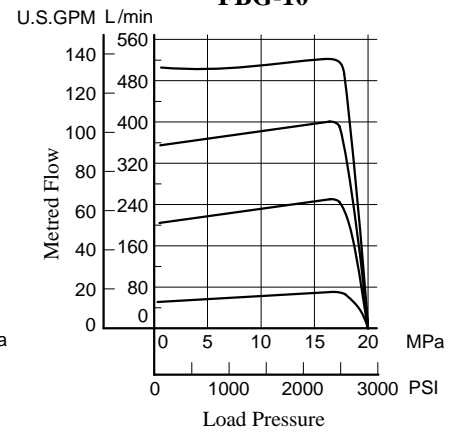

■ Metred Flow vs. Dial Position

Loading Pressure : 7 MPa(1020 PSI)

FBG-03

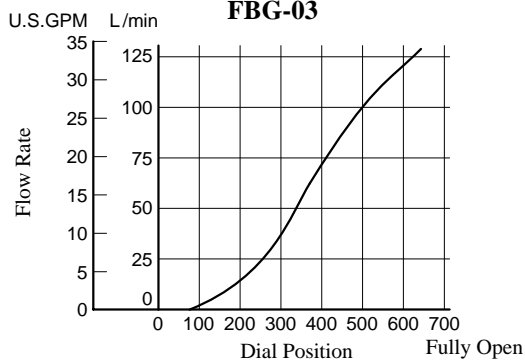

FBG-06

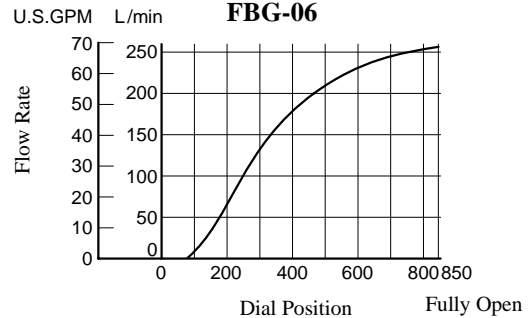

FBG-10

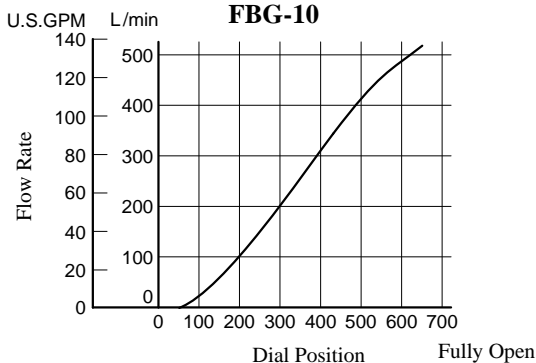

FBG-03-125-10/1090
 FBG-06-250-10/1090
 FBG-10-500-10/1090

CAUTION

When making replacement of seals, please do it carefully after reading through the relevant instructions in the Operator's Manual.

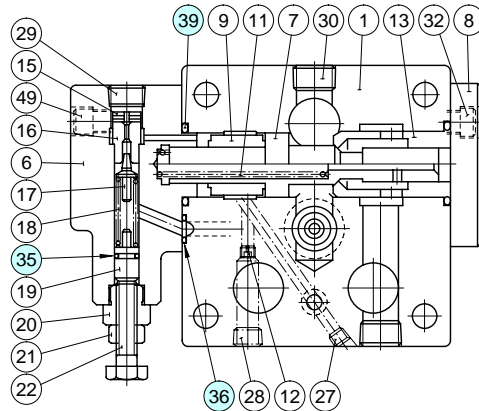

Section X-X

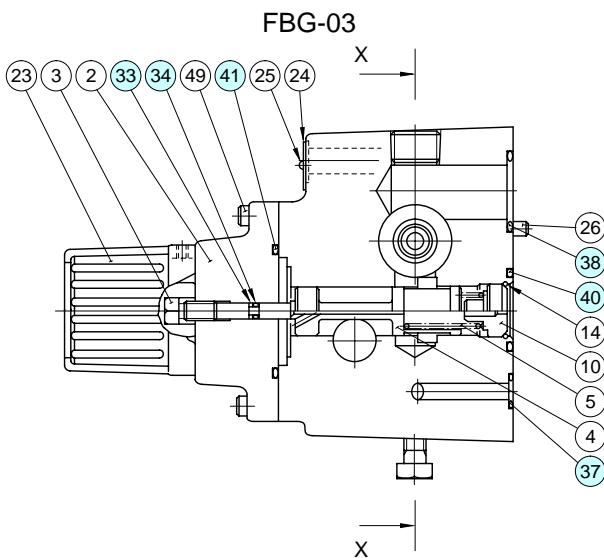

FBG-03

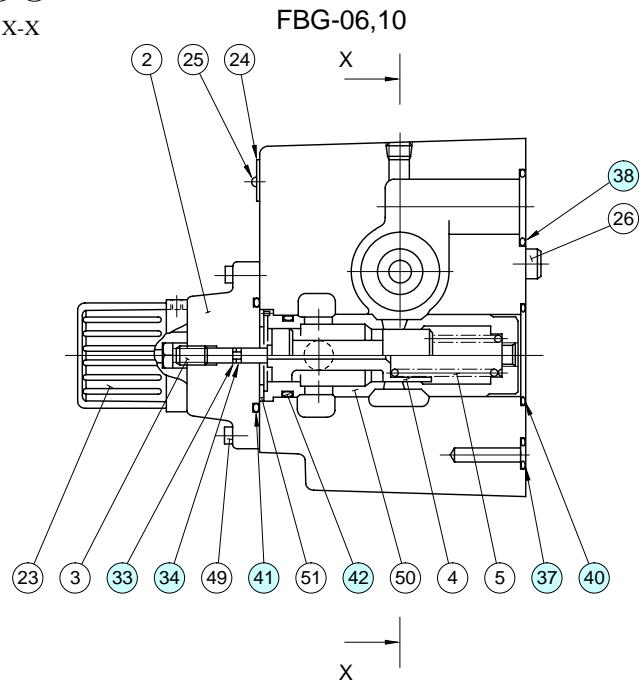

FBG-06,10

List of Seals

Item	Name of Parts	Part Numbers			Qty.
		FBG-03	FBG-06	FBG-10	
33	Back Up Ring	SO-BB-P4	SO-BB-P4	SO-BB-P4	1
34	O-Ring	SO-NA-P4	SO-NA-P4	SO-NA-P4	1
35	O-Ring	SO-NA-P9	SO-NA-P9	SO-NA-P9	1
36	O-Ring	SO-NB-P9	SO-NB-P9	SO-NB-P11	1
37	O-Ring	SO-NB-P11	SO-NB-P11	SO-NB-P11	1
38	O-Ring	SO-NB-P28	SO-NB-P32	SO-NB-P48	3
39	O-Ring	SO-NB-P32	SO-NB-P42	SO-NB-G55	2
40	O-Ring	SO-NB-G30	SO-NB-P44	SO-NB-G60	1
41	O-Ring	SO-NB-G50	SO-NB-G50	SO-NB-G50	1
42	O-Ring	—	SO-NB-P34	SO-NB-P50	1

Note: When ordering the seals, please specify the seal kit number from the table right.

List of Seal Kits

Model Numbers	Seal Kit Numbers
FBG-03	KS-FBG-03-10
FBG-06	KS-FBG-06-10
FBG-10	KS-FBG-10-10

RESTRICTORS

SRT/SRG-03/06/10 (3/8, 3/4, 1-1/4)

ONE WAY RESTRICTORS

SRCT/SRCG-03/06/10 (3/8, 3/4, 1-1/4)

Threaded Connections / Sub-plate Mounting

FLOW CONTROLS

Up to 25 MPa (3630 PSI), 500 L/min (132 U.S.GPM)

This valve is used to regulate an actuator speed in a circuit where line pressure is almost steady and small fluctuation of oil flow due to pressure changes is permitted. Integrated check valve allows reversed free flow from outlet to inlet port. Pressure balanced construction provides less effort in adjustment at high pressure.

■ Restrictors

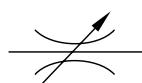
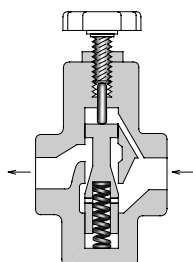

■ One Way Restrictors

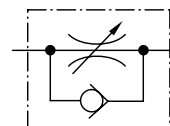
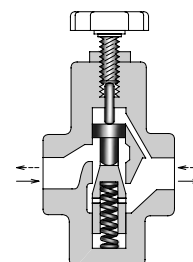

■ Hydraulic Fluids

● Fluid Types

Any type of hydraulic fluid listed in the table below can be used.

Petroleum base oils	Use fluids equivalent to ISO VG 32 or VG 46.
Synthetic fluids	Use phosphate ester or polyol ester fluid. When phosphate ester fluid is used, prefix "F-" to the model number because the special seals (fluororubber) are required to be used.
Water containing fluids	Use water-glycol fluid.

Note: For use with hydraulic fluids other than those listed above, please consult your Yuken representatives in advance.

● Recommended Viscosity and Temperatures

Viscosity ranging between 15 - 400 mm²/s (77 - 1800 SSU).

Oil temperatures between -15/+70°C (5 - 158°F).

Use hydraulic fluids which satisfy the recommended viscosity and oil temperatures given above.

● Control of Contamination

Due caution must be paid to maintaining control over contamination of the hydraulic fluids which may otherwise lead to breakdowns and shorten the life of the valves. Please maintain the degree of contamination within NAS 1638-Grade 12. Use 25 μm or finer line filter.

Specifications

Valve Name	Model Numbers		Rated Flow* L/min (U.S.GPM)	Max. Operating Pres. MPa (PSI)	Approx. Mass kg (lbs.)	
	Threaded Connection	Sub-plate Mounting			Threaded Connection	Sub-plate Mounting
Restrictor	SRT-03-50/5080/5090	SRG-03-50/5090	30 (7.9)	25 (3630)	1.5 (3.3)	2.5 (5.5)
	SRT-06-50/5080/5090	SRG-06-50/5090	85 (22.4)		3.8 (8.4)	3.9 (8.6)
	SRT-10-50/5080/5090	SRG-10-50/5090	230 (60.7)		9.1 (20.1)	7.5 (16.5)
One Way Restrictor	SRCT-03-50/5080/5090	SRCG-03-50/5090	30 (7.9)	25 (3630)	1.5 (3.3)	2.5 (5.5)
	SRCT-06-50/5080/5090	SRCG-06-50/5090	85 (22.4)		3.8 (8.4)	3.9 (8.6)
	SRCT-10-50/5080/5090	SRCG-10-50/5090	230 (60.7)		9.1 (20.1)	7.5 (16.5)

★ Rated flow stands for approximate flow rate when the pressure drop between inlet and outlet ports of the valve in fully opened condition becomes 0.3 MPa (44 PSI) maximum at fluid's specific gravity of 0.85 and kinematic viscosity of 20 mm²/s (98 SSU).

Yuken can offer flanged connection valves described below.

For details, contact us.

Model Numbers	Rated Flow L/min (U.S.GPM)	Max. Operating Pressure MPa (PSI)
SRF/SRCF-10-50 SRF/SRCF-10-5090	230 (60.7)	25 (3630)
SRF/SRCF-16-50 SRF/SRCF-16-5090	500 (132)	

Graphic Symbols

SRT / SRG

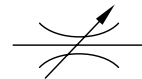

SRCT / SRCG

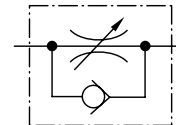

Model Number Designation

F-	SR	T	-03	-50	*
Special Seals	Series Number	Type of Mounting	Valve Size	Design Number	Design Standards
F: Special Seals for Phosphate Ester Type Fluids (Omit if not required)	SR: Restrictor	T: Threaded Connection	03	50	None: Japanese Std. "JIS" 80: European Design Std. 90: N.American Design Std.
			06	50	
			10	50	
		G: Sub-plate Mounting	03	50	
			06	50	
			10	50	
	SRC: One Way Restrictor	T: Threaded Connection	03	50	None: Japanese Std. "JIS" 80: European Design Std. 90: N.American Design Std.
			06	50	
			10	50	
		G: Sub-plate Mounting	03	50	
			06	50	
			10	50	

■ Attachment

● Mounting Bolts

Valve Model Numbers	Socket Head Cap Screw		Qty.
	Japanese Std. "JIS" and European Design Std.	N. American Design Std.	
SRG/SRCG-03	M10 × 45 Lg.	3/8-16 UNC × 1-3/4 Lg.	4
SRG/SRCG-06	M10 × 50 Lg.	3/8-16 UNC × 2 Lg.	4
SRG/SRCG-10	M10 × 55 Lg.	3/8-16 UNC × 2-1/4 Lg.	6

■ Sub-plate

Valve Model Numbers	Japanese Standard "JIS"		European Design Standard		N. American Design Standard		Approx. Mass kg (lbs.)
	Sub-plate Model Numbers	Thread Size	Sub-plate Model Numbers	Thread Size	Sub-plate Model Numbers	Thread Size	
SRG SRCG -03	CRGM-03-50	Rc 3/8	CRGM-03-5080	3/8 BSP.F	CRGM-03-5090	3/8 NPT	1.6 (3.5)
	CRGM-03X-50	Rc 1/2	CRGM-03X-5080	1/2 BSP.F	CRGM-03X-5090	1/2 NPT	1.6 (3.5)
SRG SRCG -06	CRGM-06-50	Rc 3/4	CRGM-06-5080	3/4 BSP.F	CRGM-06-5090	3/4 NPT	2.4 (5.3)
	CRGM-06X-50	Rc 1	CRGM-06X-5080	1 BSP.F	CRGM-06X-5090	1 NPT	3.0 (6.6)
SRG SRCG -10	CRGM-10-50	Rc 1-1/4	CRGM-10-5080	1-1/4 BSP.F	CRGM-10-5090	1-1/4 NPT	4.8 (10.6)
	CRGM-10X-50	Rc 1-1/2	CRGM-10X-5080	1-1/2 BSP.F	CRGM-10X-5090	1-1/2 NPT	5.7 (12.6)

- Sub-plates are available. Specify the sub-plate model number from the table above. When sub-plates are not used, the mounting surface should have a good machined finish.

■ Instructions

● Flow Adjustment

Slacken the lock nut and turn the flow adjustment knob anti-clockwise to throttle flow. After achieving satisfactory performance tighten the lock nut.

SRT/SRCT-03-50/5080/5090
SRT/SRCT-06-50/5080/5090
SRT/SRCT-10-50/5080/5090

DIMENSIONS IN
MILLIMETRES (INCHES)

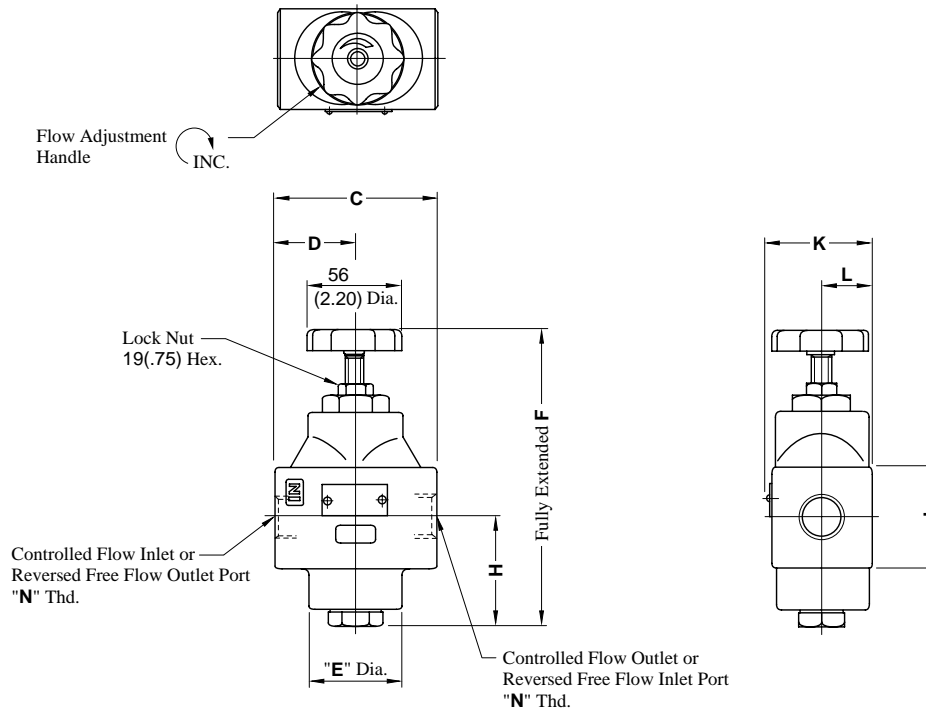

Model Numbers	Dimensions mm (Inches)								Thd. Size
	C	D	E	F	H	J	K	L	"N" Thd.
SRT/SRCT-03-50	72	36	44	150.5	53.5	38	46	22	Rc 3/8
SRT/SRCT-03-5080	(2.83)	(1.42)	(1.73)	(5.93)	(2.11)	38 Dia.	(1.81)	(.87)	3/8 BSP.F
SRT/SRCT-03-5090									3/8 NPT
SRT/SRCT-06-50	100	50	58	180	66.5	62	64	31	Rc 3/4
SRT/SRCT-06-5080	(3.94)	(1.97)	(2.28)	(7.09)	(2.62)	62 Sq.	(2.52)	(1.22)	3/4 BSP.F
SRT/SRCT-06-5090									3/4 NPT
SRT/SRCT-10-50	138	69	80	227	86	80	82	40	Rc 1-1/4
SRT/SRCT-10-5080	(5.43)	(2.72)	(3.15)	(8.94)	(3.39)	80 Sq.	(3.23)	(1.57)	1-1/4 BSP.F
SRT/SRCT-10-5090									1-1/4 NPT

SRG/SRCG-03-50/5090

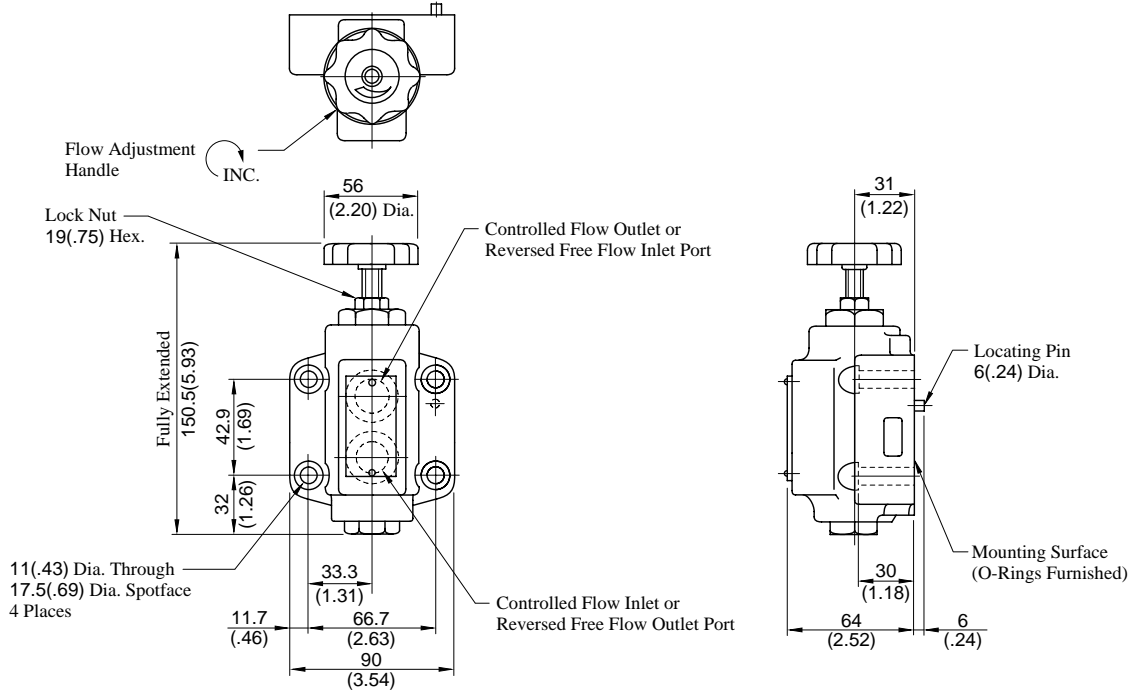

DIMENSIONS IN
MILLIMETRES (INCHES)

■ Sub-plate

CRGM-⁰³_{03X}-50/5080/5090

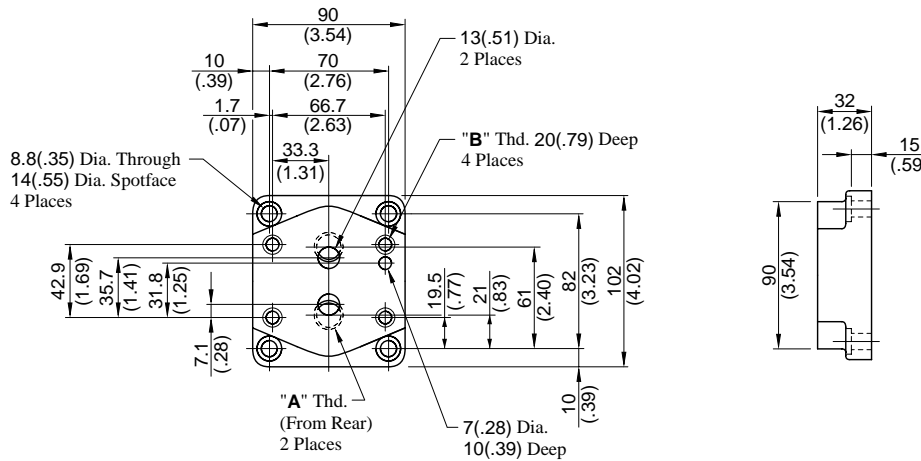

Sub-plate Model Numbers	"A" Thd.	"B" Thd.
CRGM-03-50	Rc 3/8	M10
CRGM-03-5080	3/8 BSP.F	
CRGM-03-5090	3/8 NPT	3/8-16 UNC
CRGM-03X-50	Rc 1/2	M10
CRGM-03X-5080	1/2 BSP.F	
CRGM-03X-5090	1/2 NPT	3/8-16 UNC

SRG/SRCG-06-50/5090

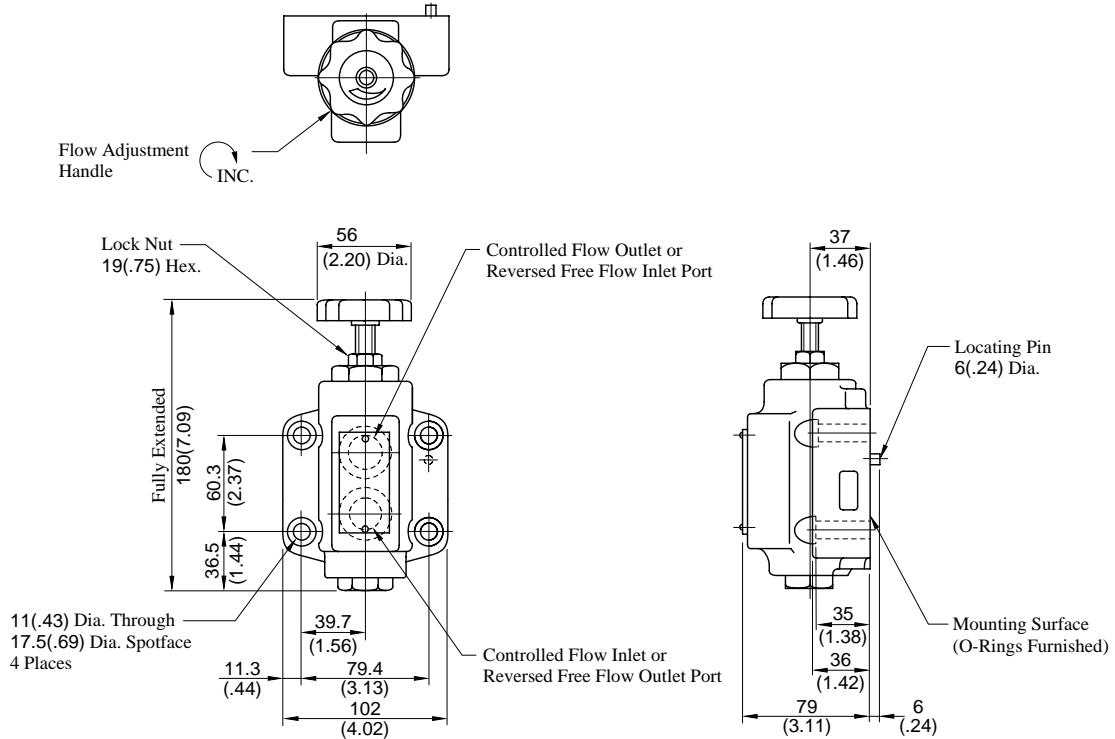

**DIMENSIONS IN
MILLIMETRES (INCHES)**

Sub-plate

CRGM-06 06X-50/5080/5090

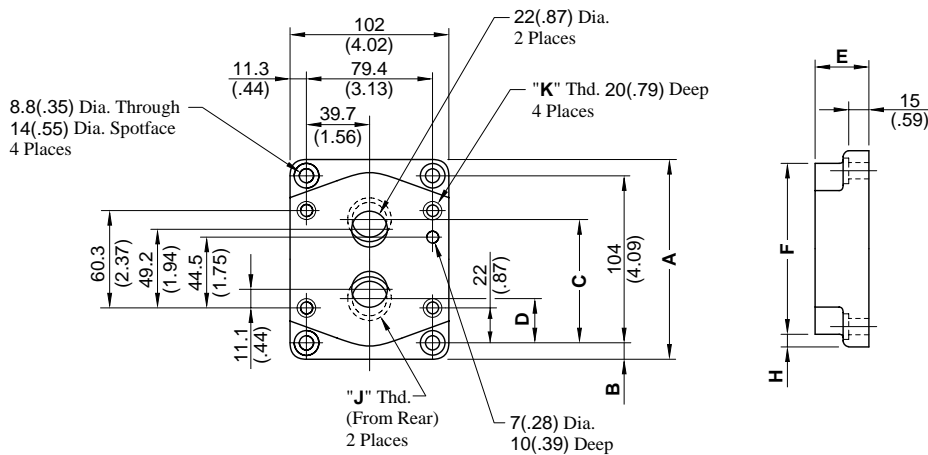

Sub-plate Model Numbers	Dimensions mm (Inches)							"J" Thd.	"K" Thd.
	A	B	C	D	E	F	H		
CRGM-06-50	124 (4.88)	10 (.39)	77 (3.03)	27 (1.06)	36 (1.42)	110 (4.33)	7 (.28)	Rc 3/4	M10
CRGM-06-5080								3/4 BSP.F	
CRGM-06-5090								3/4 NPT	
CRGM-06X-50	136 (5.35)	16 (.63)	82.3 (3.24)	22 (.87)	45 (1.77)	136 (5.35)	0	Rc 1	M10
CRGM-06X-5080			80 (3.15)	24 (.94)				1 BSP.F	
CRGM-06X-5090			82.3 (3.24)	22 (.87)				1 NPT	

SRG/SRCG-10-50/5090

Mounting surface: ISO 5781-AJ-10-2-A

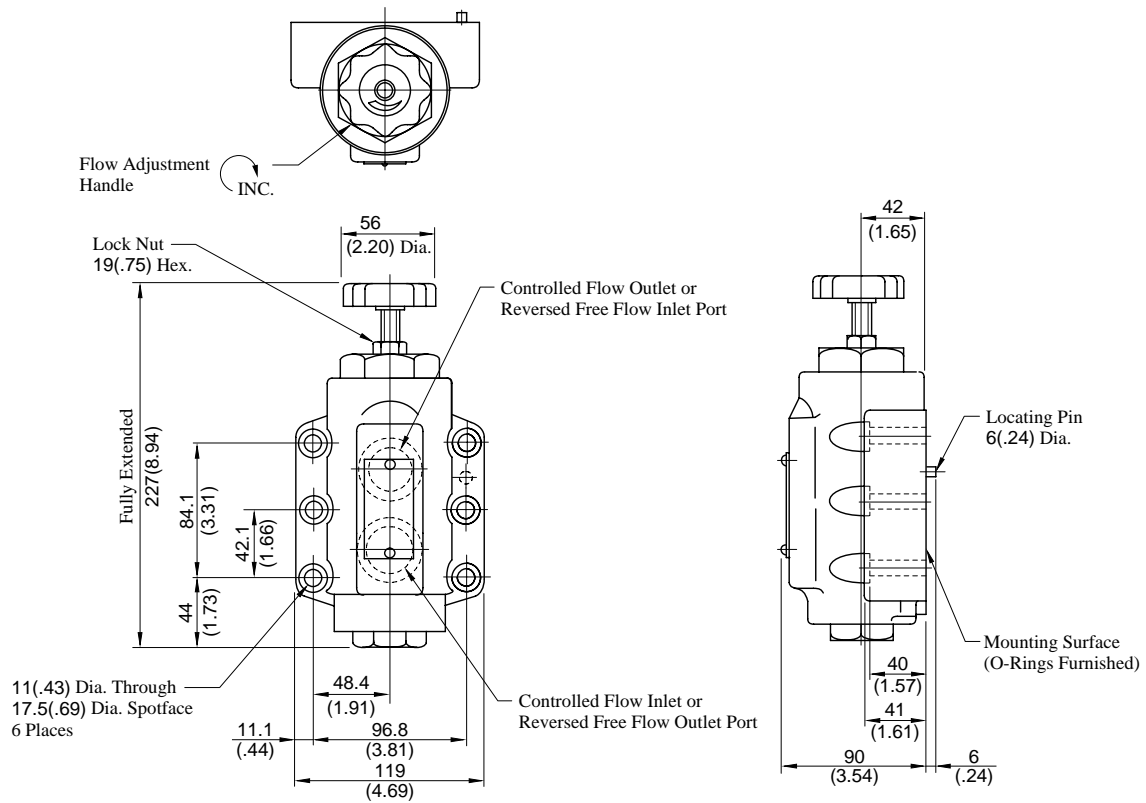

DIMENSIONS IN MILLIMETRES (INCHES)

Sub-plate

CRGM-10-50/5080/5090

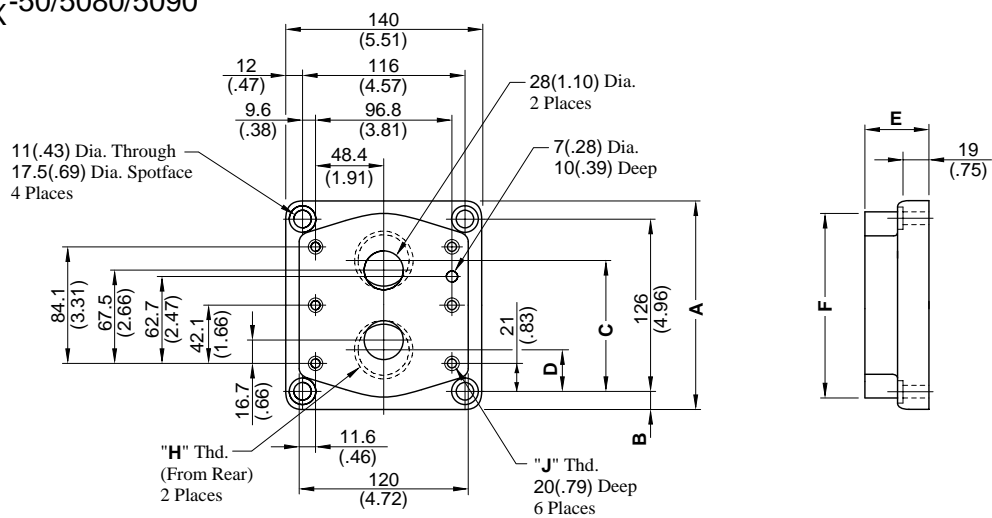

Sub-plate Model Numbers	Dimensions mm (Inches)						"H" Thd.	"J" Thd.
	A	B	C	D	E	F		
CRGM-10-50							Rc 1-1/4	M10
CRGM-10-5080	150 (5.91)	12 (.47)	96 (3.78)	30 (1.18)	45 (1.77)	135 (5.31)	1-1/4 BSP.F	
CRGM-10-5090							1-1/4 NPT	
CRGM-10X-50							Rc 1-1/2	M10
CRGM-10X-5080	177 (6.97)	25.5 (1.00)	104 (4.09)	22 (.87)	50 (1.97)	167 (6.57)	1-1/2 BSP.F	
CRGM-10X-5090							1-1/2 NPT	

Hydraulic Fluid: Viscosity 30 mm²/s (141 SSU), Specific Gravity 0.850

Metred Flow vs Adjustment Handle Revolutions

ΔP: Differential Pressure MPa (PSI)

● SRT SRG-03, SRCT SRCG-03

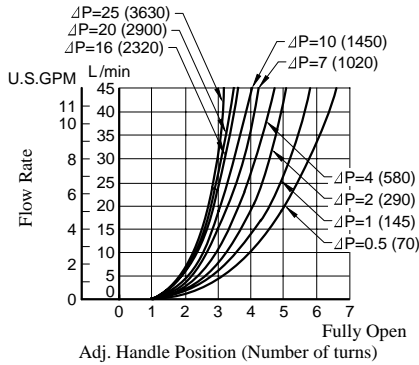

● SRT SRG-06, SRCT SRCG-06

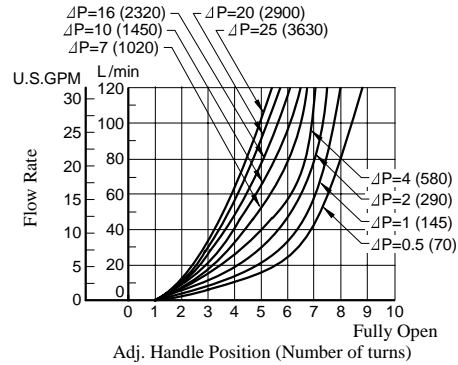

● SRT SRG-10, SRCT SRCG-10

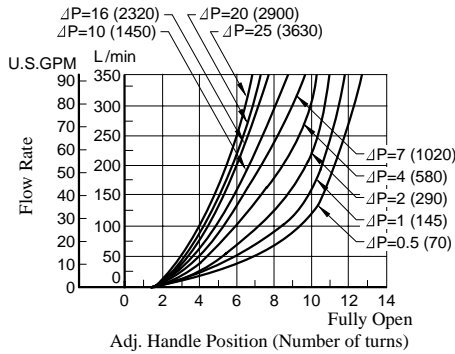

Pressure Drop

● SRT SRG-03, SRCT SRCG-03

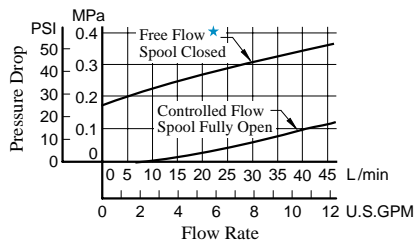

● SRT SRG-06, SRCT SRCG-06

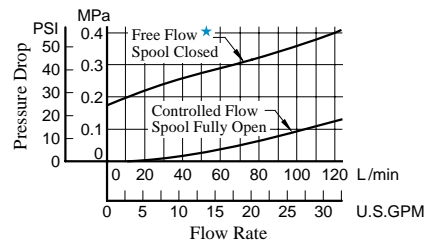

● SRT SRG-10, SRCT SRCG-10

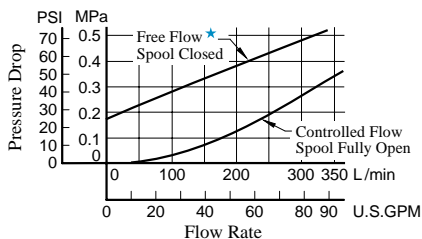

★ Applicable only for one way restrictor (Model No. SRC*)

SRT/SRCT-03-50/5080/5090
SRT/SRCT-06-50/5080/5090
SRT/SRCT-10-50/5080/5090

⚠ CAUTION

When making replacement of seals, please do it carefully after reading through the relevant instructions in the Operator's Manual.

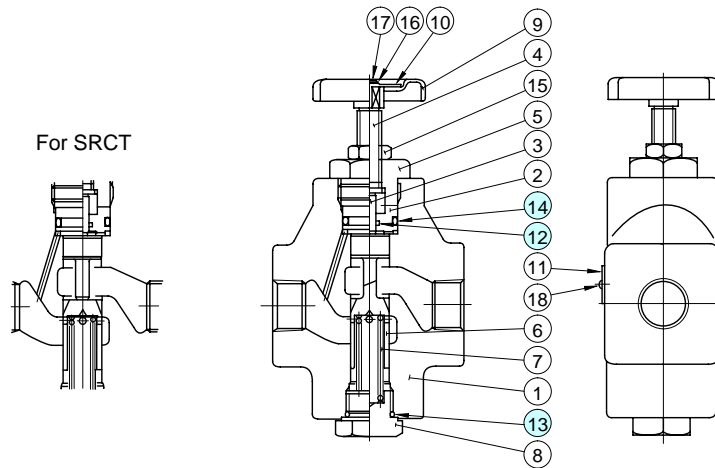

● List of Seals

Item	Name of Parts	Part Numbers			Qty.
		SRT SRCT-03	SRT SRCT-06	SRT SRCT-10	
12	O-Ring	SO-NB-P7	SO-NB-P7	SO-NB-P7	1
13	O-Ring	SO-NB-P15	SO-NB-P21	SO-NB-P29	1
14	O-Ring	SO-NB-P20	SO-NB-P22.4	SO-NB-P36	1

Note: When ordering the seals, please specify the seal kit number from the table right.

● List of Seal Kits

Model Numbers	Seal Kit Numbers
SRT/SRCT-03	KS-SRT-03-50
SRT/SRCT-06	KS-SRT-06-50
SRT/SRCT-10	KS-SRT-10-50

SRG/SRCG-03-50/5090
SRG/SRCG-06-50/5090
SRG/SRCG-10-50/5090

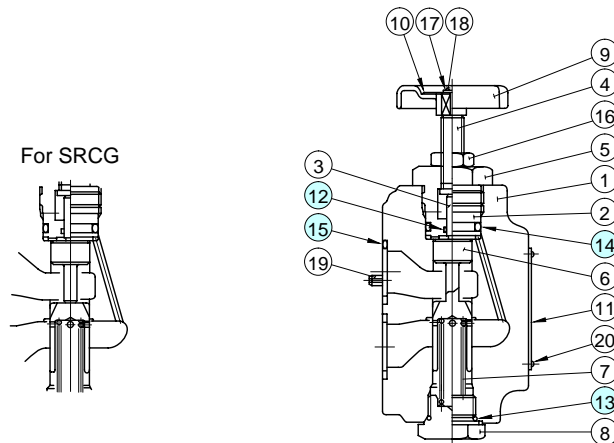

● List of Seals

Item	Name of Parts	Part Numbers			Qty.
		SRG SRCG-03	SRG SRCG-06	SRG SRCG-10	
12	O-Ring	SO-NB-P7	SO-NB-P7	SO-NB-P7	1
13	O-Ring	SO-NB-P15	SO-NB-P21	SO-NB-P29	1
14	O-Ring	SO-NB-P20	SO-NB-P22.4	SO-NB-P36	1
15	O-Ring	SO-NB-P18	SO-NB-P28	SO-NB-P32	2

Note: When ordering the seals, please specify the seal kit number from the table right.

● List of Seal Kits

Model Numbers	Seal Kit Numbers
SRG/SRCG-03	KS-SRG-03-50
SRG/SRCG-06	KS-SRG-06-50
SRG/SRCG-10	KS-SRG-10-50



THROTTLE MODULES TC1G-01 / 03 (1 / 8 , 3 / 8) THROTTLE AND CHECK MODULES TC2G-01 / 03 (1 / 8 , 3 / 8) Gasket Mounting

FLOW
CONTROLS

Specifications / Model Number Designation

Up to 25 MPa (3630 PSI), 80 L/min (21.1 U.S.GPM)

Used as pilot choke valves for solenoid controlled pilot operated directional valves and pilot operated directional valves.

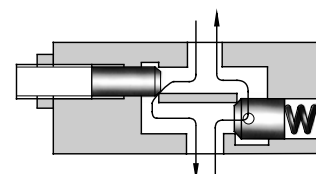
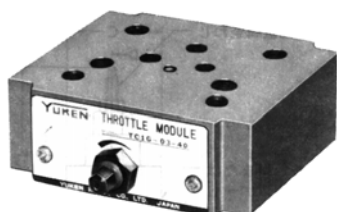

Graphic Symbols

Valve Size	Throttle Modules		Throttle and Check Modules	
	Standard Type	With Check	Standard (Metre-out) Type	Metre-in Type
01	<div style="border: 1px solid black; padding: 2px; width: fit-content; margin: 0 auto;">Solenoid Operated Directional Valve</div> P A B T TC1G-01	 P A B T TC1G-01-C	<div style="border: 1px solid black; padding: 2px; width: fit-content; margin: 0 auto;">Solenoid Operated Directional Valve</div> P A B T TC2G-01	 P A B T TC2G-01-A
03	<div style="border: 1px solid black; padding: 2px; width: fit-content; margin: 0 auto;">Solenoid Operated Directional Valve</div> P A B T TC1G-03	<div style="border: 1px solid black; padding: 2px; width: fit-content; margin: 0 auto;">Solenoid Operated Directional Valve</div> P A B T TC1G-03-C	<div style="border: 1px solid black; padding: 2px; width: fit-content; margin: 0 auto;">Solenoid Operated Directional Valve</div> P A B T TC2G-03	<div style="border: 1px solid black; padding: 2px; width: fit-content; margin: 0 auto;">Solenoid Operated Directional Valve</div> P A B T TC2G-03-A

Specifications

Model Numbers	Nominal Flow L/min (U.S.GPM)	Max Operating Pressure MPa (PSI)	Approx. Mass kg (lbs.)
TC1G-01-40/4090	30 (7.9)	25 (3630)	0.6 (1.3)
TC2G-01-40/4090			0.65 (1.4)
TC1G-03-*40/4090	80 (21.1)		1.6 (3.5)
TC2G-03-*40/4090			1.8 (4.0)

Model Number Designation

F-	TC1	G	-03	-C	-40	*
Special Seals	Series Number	Type of Mounting	Valve Size	Valve Type	Design Number	Design Standards
F-: Special Seals for Phosphate Ester Type Fluids (Omit if not required)	TC1: Throttle Module	G: Gasket Mounting	01	None: Std. Type	40	None: Japanese Std. "JIS" and European Design Std. 90: N. American Design Std.
	TC2: Throttle and Check Module			None: Std. (Metre-Out) Type		
	TC1: Throttle Module	G: Gasket Mounting	03	None: Std. Type C: With Check Valve	40	
	TC2: Throttle and Check Module			None: Std. (Metre-Out) Type A: Metre-in Type		



Hydraulic Fluids

Fluid Types

Any type of hydraulic fluids listed in the table below can be used.

Petroleum base oils	Use fluids equivalent to ISO VG 32 or VG 46.
Synthetic fluids	Use phosphate ester or polyol ester fluid. When phosphate ester fluid is used, prefix "F-" to the model number because the special seals (fluororubber) are required to be used.
Water containing fluids	Use water-glycol fluid.

Note: For use with hydraulic fluids other than those listed above, please consult your Yuken representatives in advance.

Recommended Viscosity and Oil Temperatures

Viscosity ranging between 15 - 400 mm²/s (77 - 1800 SSU).

Oil temperatures between -15/+70°C (5 - 158°F).

Use hydraulic fluids which satisfy the recommended viscosity and oil temperatures given above.

Control of Contamination

Due caution must be paid to maintaining control over contamination of the hydraulic fluids which may otherwise lead to breakdowns and shorten the life of the valves. Please maintain the degree of contamination within NAS 1638-Grade 12. Use 25 µm or finer line filter.

Attachment

Mounting Bolts

If mounting bolts are necessary, order suitable ones selected from the table below. If mounting bolts from other companies are used, their strength must be 8.8 or up ISO standards.

Solenoid Operated Directional Valve	Valve Model Numbers	Socket Head Cap Screw		Qty.
		Japanese Std. "JIS" & European Design Std.	N. American Design Std.	
	TC*G-01	M5 × 70 Lg.	No. 10-24 UNC × 2-3/4 Lg.	4
	TC*G-03	M6 × 70 Lg.	1/4-20 UNC × 2-3/4 Lg.	4
	TC*G-01	M5 × 95 Lg.	No. 10-24 UNC × 3-3/4 Lg.	4
	TC*G-03	M6 × 100 Lg.	1/4-20 UNC × 4 Lg.	4

Instructions

Flow adjustment

Slacken the lock nut and turn the flow adjustment screw clockwise caused the flow rate to decrease
After adjustment, be sure to tighten the lock nut.

TC2G-01-40/4090

Mounting surface: ISO 4401-AB-03-4-A

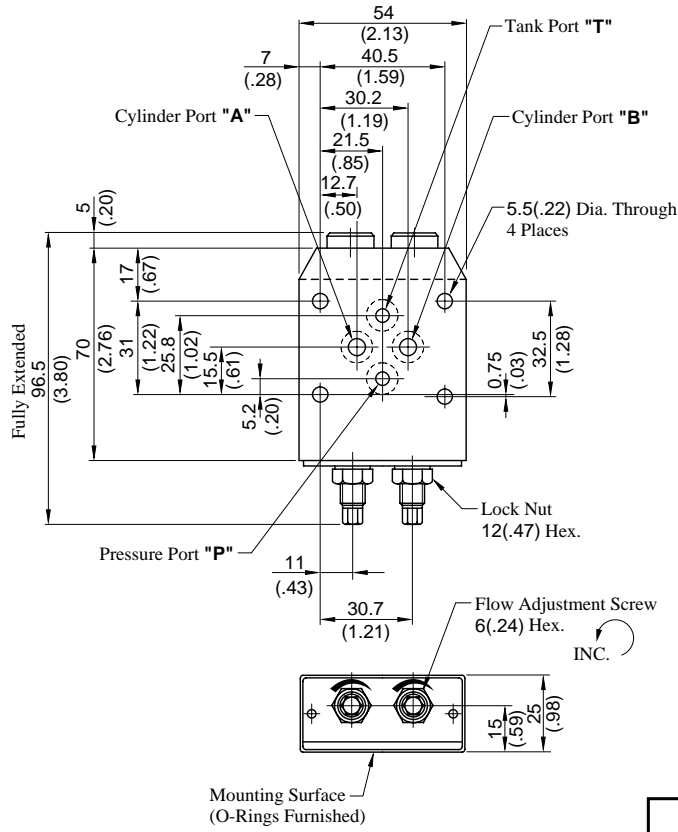

**DIMENSIONS IN
MILLIMETRES (INCHES)**

TC1G-01-40/4090

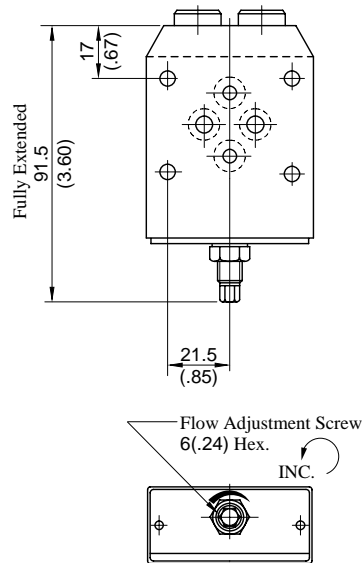

Note: For other dimensions, see the figures shown TC2G-01.

D

TC2G-03-40/4090
TC2G-03-A-40/4090

Mounting surface: ISO 4401-AC-05-4-A

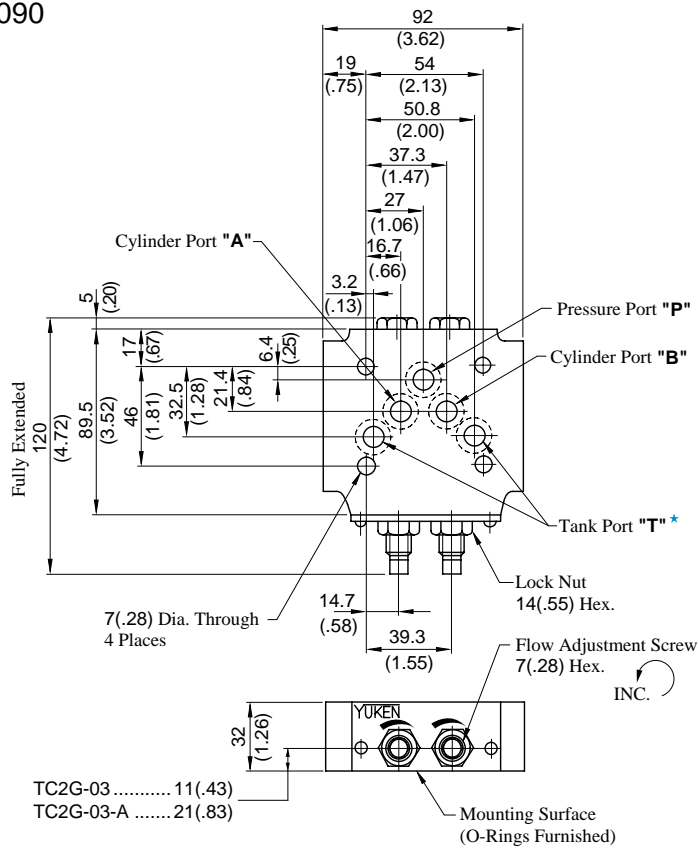

★ With standard sub-plates, the left one of the two tank ports "T" is used but either one may be used.

DIMENSIONS IN
MILLIMETRES (INCHES)

TC1G-03-40/4090
TC1G-03-C-40/4090

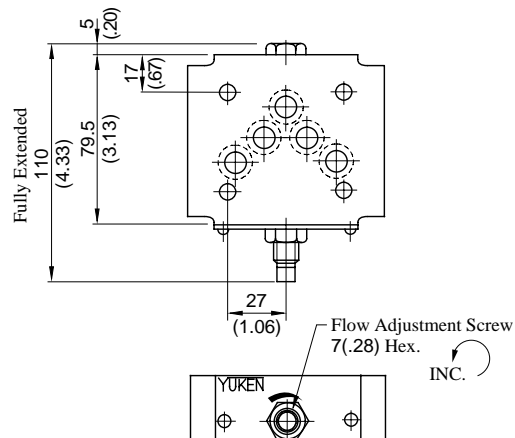

Note: For other dimensions, see the figures shown TC2G-03.

Hydraulic Fluid: Viscosity 35 mm²/s (164 SSU) , Specific Gravity 0.850

Metred Flow vs. Adjustment Revolutions

Pressure Drop

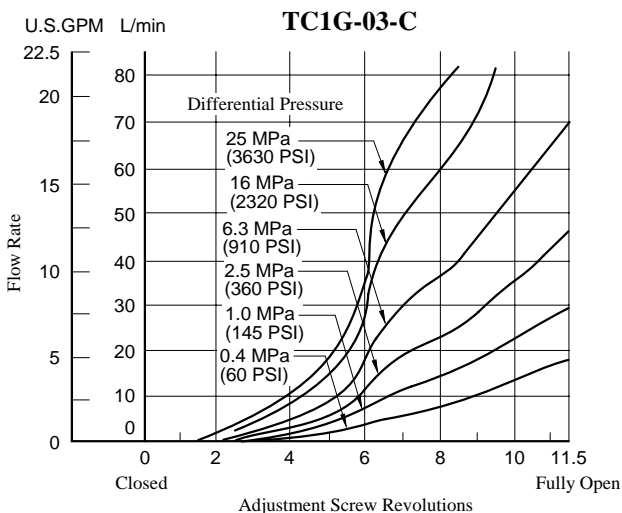
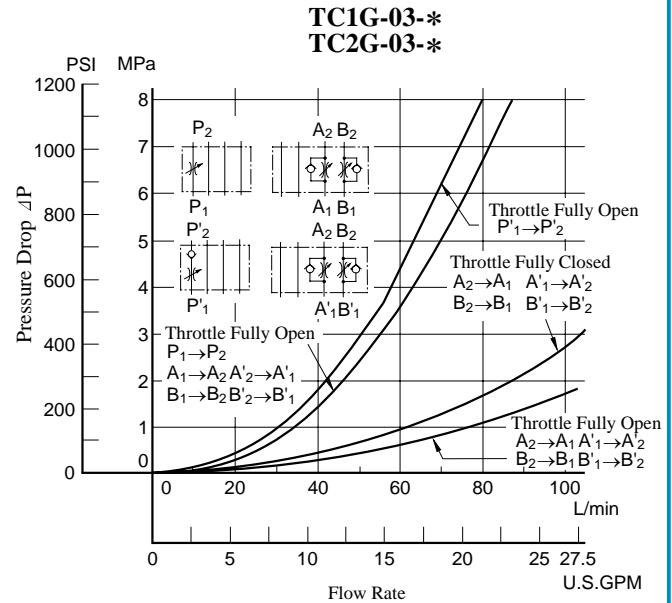
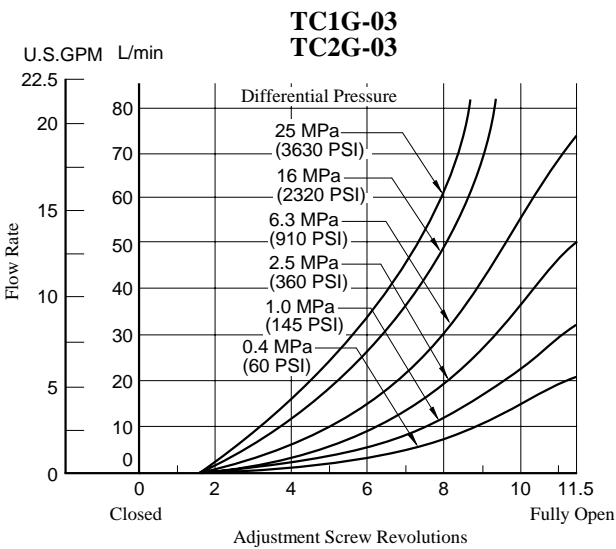
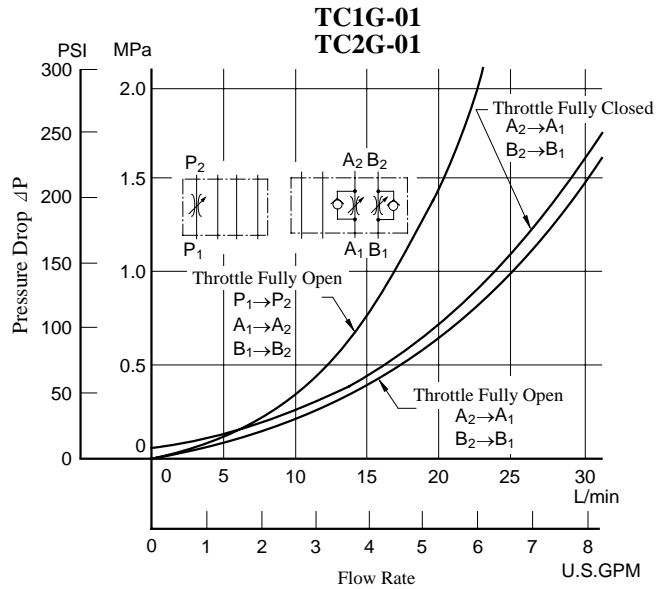
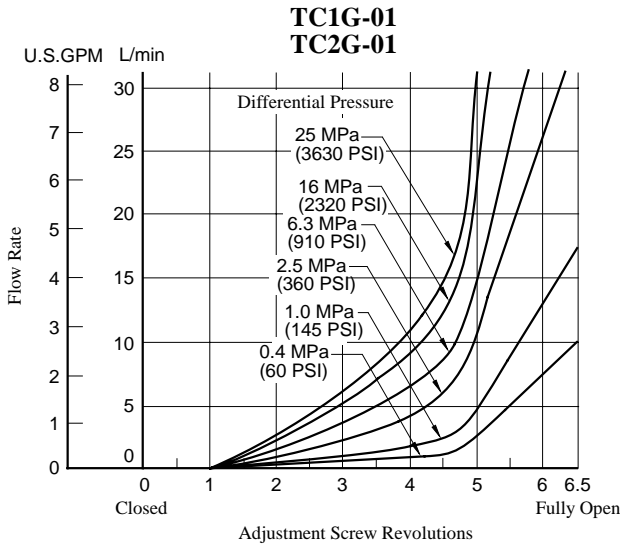

- For any other viscosity, multiply the factors in the table below.

Viscosity	mm ² /s	15	20	30	40	50	60	70	80	90	100
	SSU		77	98	141	186	232	278	324	371	417
Factor		0.81	0.87	0.96	1.03	1.09	1.14	1.19	1.23	1.27	1.30

- For any other specific gravity (G'), the pressure drop ($\Delta P'$) may be obtained from the formula below.
 $\Delta P' = \Delta P (G'/0.850)$



TC1G-01-40/4090
TC1G-03-*-40/4090

⚠ CAUTION

When making replacement of seals, please do it carefully after reading through the relevant instructions in the Operator's Manual.

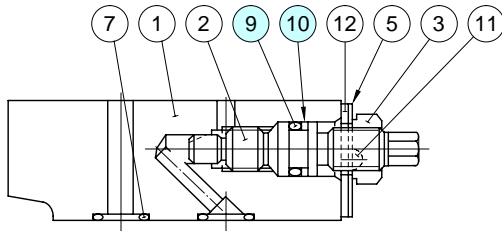

TC1G-01

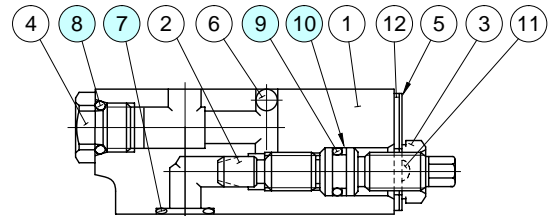

TC1G-03

● List of Seals

Item	Name of Parts	Part Numbers		Qty.
		TC1G-01	TC1G-03	
7	O-Ring	SO-NB-P9	SO-NB-A014	5 *
8	O-Ring	—	SO-NB-P10	1
9	O-Ring	SO-NA-P7	SO-NA-P9	1
10	Back Up Ring	SO-BB-P7	SO-BB-P9	1

★ With TC1G-01, 4 O-Rings, Item ⑦, are used.

Note: When ordering the seals, please specify the seal kit number from the table right

● List of Seal Kits

Model Numbers	Seal Kit Numbers
TC1G-01	KS-TC1G-01-40
TC1G-03	KS-TC1G-03-40
TC1G-03-C	

TC2G-01-40/4090
TC2G-03-*-40/4090

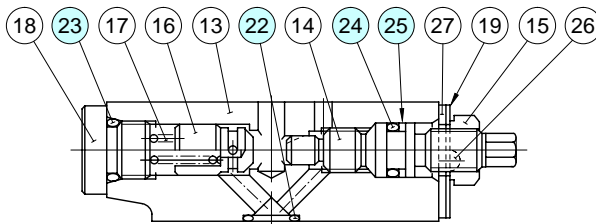

TC2G-01

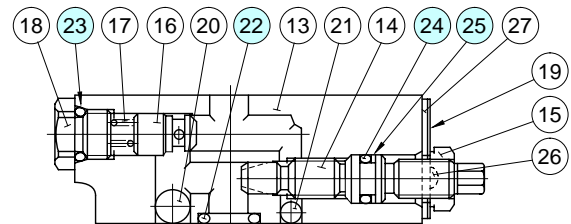

TC2G-03

● List of Seals

Item	Name of Parts	Part Numbers		Qty.
		TC2G-01	TC2G-03	
22	O-Ring	SO-NB-P9	SO-NB-A014	5 *
23	O-Ring	SO-NB-P10	SO-NB-P10	2
24	O-Ring	SO-NA-P7	SO-NA-P9	2
25	Back Up Ring	SO-BB-P7	SO-BB-P9	2

★ With TC2G-01, 4 O-Rings, Item ②, are used.

Note: When ordering the seals, please specify the seal kit number from the table right

● List of Seal Kits

Model Numbers	Seal Kit Numbers
TC2G-01	KS-TC2G-01-40
TC2G-03	KS-TC2G-03-40
TC2G-03-A	



DECELERATION VALVES
ZT / ZG-03 / 06 / 10 (3/8, 3/4, 1-1/4)
DECELERATION AND CHECK VALVES
ZCT / ZCG-03 / 06 / 10 (3/8, 3/4, 1-1/4)
Threaded Connections / Sub-plate Mounting

FLOW CONTROLS

Specifications / Model Number Designation

Up to 21 MPa (3050 PSI), 200 L/min (52.8 U.S.GPM)

These valves are available either with or without an integral check valve which allows free reverse flow. Flow rate through the valve is regulated by the movement of the spool, which is operated by a cam. When the spool is depressed, the flow is decreased in Normally Open type valves and increased in Normally Closed type valves. Their principal use is to control the speed of actuators in machine tools and similar applications.

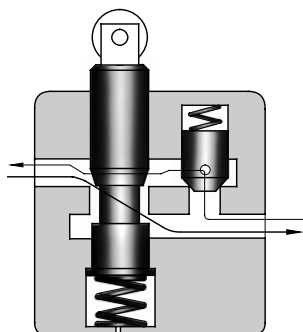

Normally Open Type

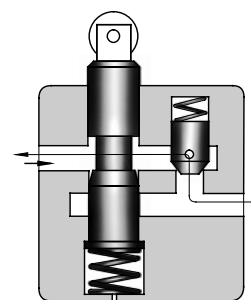

Normally Closed Type

Specifications

Model Numbers		Max. Flow L/min (U.S.GPM)	Max. Operating Pressure MPa (PSI)	Approx. Mass kg (lbs.)	
Threaded Connection	Sub-plate Mounting			Z*T	Z*G
ZT/ZCT-03-*-*-22/2280/2290	ZG/ZCG-03-*-*-22/2290	30 (7.9)	21 (3050)	4.3 (9.5)	4.3 (9.5)
ZT/ZCT-06-*-*-22/2280/2290	ZG/ZCG-06-*-*-22/2290	80 (21.1)		8.7 (19.2)	8.7 (19.2)
ZT/ZCT-10-*-*-22/2280/2290	ZG/ZCG-10-*-*-22/2290	200 (52.8)		17 (37.5)	17 (37.5)

Model Number Designation

F-	ZC	T	-03	-T	-C	-22	*	
Special Seals	Series Number	Type of Mounting	Valve Size	With Adjustable Needle Valve for By-Pass Line	Spool Type	Design Number	Design Standards	
F: Special Seals for Phosphate Ester Type Fluids (Omit if not required)	Z: Deceleration Valve	T: Threaded Connection	03	T: With Adjustable Needle Valve (Omit if not required)	None: Normally Open Type	22	None: Japanese Std. "JIS" 80: European Design Std. 90: N. American Design Std.	
			06			22		
			10			22		
		G: Sub-plate Mounting	03			C: Normally Closed Type	22	None: Japanese Std. "JIS" & European Design Std. 90: N. American Design Std.
			06				22	
			10				22	
	ZC: Deceleration and Check Valve	T: Threaded Connection	03	T: With Adjustable Needle Valve (Omit if not required)	None: Normally Open Type	22	None: Japanese Std. "JIS" 80: European Design Std. 90: N. American Design Std.	
			06			22		
			10			22		
		G: Sub-plate Mounting	03			C: Normally Closed Type	22	None: Japanese Std. "JIS" & European Design Std. 90: N. American Design Std.
			06				22	
			10				22	

Graphic Symbols

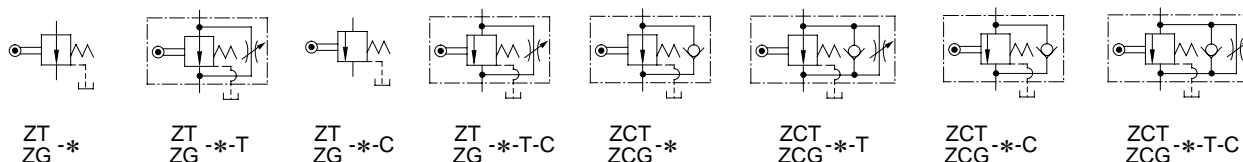

Hydraulic Fluids

Fluid Types

Any type of hydraulic fluids listed in the table below can be used.

Petroleum base oils	Use fluids equivalent to ISO VG 32 or VG 46.
Synthetic fluids	Use phosphate ester or polyol ester fluid. When phosphate ester fluid is used, prefix "F-" to the model number because the special seals (fluororubber) are required to be used.
Water containing fluids	Use water-glycol fluid.

Note: For use with hydraulic fluids other than those listed above, please consult your Yuken representatives in advance.

Recommended Viscosity and Oil Temperatures

Viscosity ranging between 15 - 400 mm²/s (77 to 1800 SSU).

Oil temperatures between -15/+70°C (5 - 158°F).

Use hydraulic fluids which satisfy the recommended viscosity and oil temperatures given above.

Control of Contamination

Due caution must be paid to maintaining control over contamination of the hydraulic fluids which may otherwise lead to breakdowns and shorten the life of the valves. Please maintain the degree of contamination within NAS 1638-Grade 12. Use 25 μm or finer line filter.

Instructions

Force to Depress Spool

Model Numbers	Force N (lbs.)
ZT/ZG ZCT/ZCG -03	150 (337)
ZT/ZG ZCT/ZCG -06	270 (607)
ZT/ZG ZCT/ZCG -10	400 (899)

Total Leakage at Spool Fully Closed

[Viscosity:20 mm²/s (98 SSU)]

Model Numbers	Total Leakage cm ³ /min (cu.in./min)				
	Pressure MPa (PSI)				
	1 (145)	2 (290)	5 (730)	10 (1450)	21 (3050)
ZT/ZG ZCT/ZCG -03	9 (.55)	18 (1.10)	44 (2.7)	88 (5.4)	185 (11.3)
ZT/ZG ZCT/ZCG -06	9 (.55)	17 (1.04)	43 (2.6)	86 (5.2)	180 (11.0)
ZT/ZG ZCT/ZCG -10	10 (.61)	20 (1.22)	49 (3.0)	98 (6.0)	205 (12.5)

Drain Port Back Pressure

Limit the drain port back pressure to 0.1 MPa (15 PSI).

In addition, connect the drain pipe independently and directly to the tank.

Attachment

Mounting Bolts

Valve Model Numbers	Socket Head Cap Screw		Qty.
	Japanese Std. "JIS" and European Design Std.	N. American Design Std.	
ZG/ZCG-03	M8 × 75 Lg.	5/16-18 UNC × 3 Lg.	4
ZG/ZCG-06	M10 × 100 Lg.	3/8-16 UNC × 4 Lg.	4
ZG/ZCG-10	M12 × 120 Lg.	1/2-13 UNC × 4-3/4 Lg.	4

Option

Bypass throttle valves

To allow a metred flow between ports even when the flow is stopped by the spool.

Sub-plate

Valve Model Numbers	Japanese Standard "JIS"		European Design Standard		N.American Design Standard		Approx. Mass kg (lbs.)
	Sub-plate Model No.	Thread Size	Sub-plate Model No.	Thread Size	Sub-plate Model No.	Thread Size	
ZG/ZCG-03	ZGM-03-21	Rc 3/8	ZGM-03-2180	3/8 BSP.F	ZGM-03-2190	3/8 NPT	2 (4.4)
ZG/ZCG-06	ZGM-06-21	Rc 3/4	ZGM-06-2180	3/4 BSP.F	ZGM-06-2190	3/4 NPT	3.8 (8.4)
ZG/ZCG-10	ZGM-10-21	Rc 1-1/4	ZGM-10-2180	1-1/4 BSP.F	ZGM-10-2190	1-1/4 NPT	9 (19.8)

- Sub-plates are available. Specify the sub-plate model number from the table above. When sub-plates are not used, the mounting surface should have a good machined finish.

ZT/ZCT-03-*-22/2280/2290
 ZT/ZCT-06-*-22/2280/2290
 ZT/ZCT-10-*-22/2280/2290

**DIMENSIONS IN
MILLIMETRES (INCHES)**

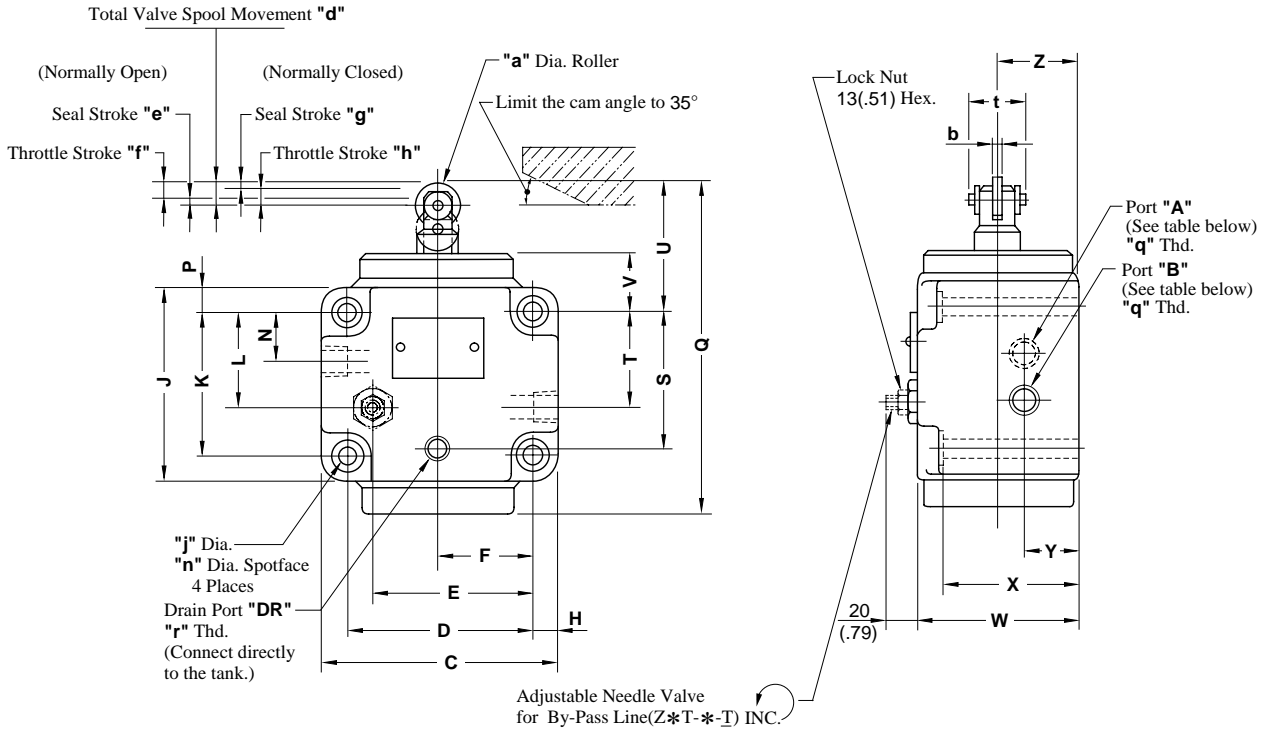

Model Numbers	Port "A"	Port "B"
ZT-*	Controlled flow inlet	Controlled flow outlet
ZCT-*	Controlled flow inlet or Reversed free flow outlet	Controlled flow outlet or Reversed free flow inlet

Model Numbers	"q" Thd.	"r" Thd.
ZT/ZCT-03-*-22	Rc 3/8	Rc 1/4
ZT/ZCT-03-*-2280	3/8 BSP.F	1/4 BSP.F
ZT/ZCT-03-*-2290	3/8 NPT	1/4 NPT
ZT/ZCT-06-*-22	Rc 3/4	Rc 1/4
ZT/ZCT-06-*-2280	3/4 BSP.F	1/4 BSP.F
ZT/ZCT-06-*-2290	3/4 NPT	1/4 NPT
ZT/ZCT-10-*-22	Rc 1-1/4	Rc 1/4
ZT/ZCT-10-*-2280	1-1/4 BSP.F	1/4 BSP.F
ZT/ZCT-10-*-2290	1-1/4 NPT	1/4NPT

Model Numbers	Dimensions mm (Inches)															
	C	D	E	F	H	J	K	L	N	P	Q	S	T	U	V	W
ZT/ZCT-03	102 (4.02)	80 (3.15)	66 (2.60)	40 (1.57)	11 (.43)	82 (3.23)	60 (2.36)	41 (1.61)	20 (.79)	11 (.43)	141 (5.55)	58 (2.28)	40 (1.57)	56 (2.20)	25 (.98)	70 (2.76)
ZT/ZCT-06	120 (4.72)	98 (3.86)	82 (3.23)	49 (1.93)	11 (.43)	106 (4.17)	84 (3.31)	57 (2.24)	32 (1.26)	11 (.43)	176 (6.93)	81 (3.19)	57 (2.24)	65 (2.56)	27 (1.06)	95 (3.74)
ZT/ZCT-10	160 (6.30)	132 (5.20)	103 (4.06)	66 (2.60)	14 (.55)	140 (5.51)	112 (4.41)	75 (2.95)	40 (1.57)	14 (.55)	224 (8.82)	106 (4.17)	75 (2.95)	80 (3.15)	32 (1.26)	110 (4.33)

Model Numbers	Dimensions mm (Inches)												
	X	Y	Z	a	b	d	e	f	g	h	j	n	t
ZT/ZCT-03	60 (2.36)	25 (.98)	35 (1.38)	18 (.71)	6 (.24)	10 (.39)	2 (.08)	8 (.31)	2 (.08)	8 (.31)	8.8 (.35)	14 (.55)	24.5 (.96)
ZT/ZCT-06	85 (3.35)	32 (1.26)	50 (1.97)	22 (.87)	8 (.31)	13 (.51)	3 (.12)	10 (.39)	3 (.12)	10 (.39)	11 (.43)	17.5 (.69)	29 (1.14)
ZT/ZCT-10	96 (3.78)	40 (1.57)	55 (2.17)	28 (1.10)	10 (.39)	18 (.71)	3 (.12)	15 (.59)	3 (.12)	15 (.59)	13.5 (.53)	21 (.83)	34 (1.34)

ZG/ZCG-03-*-22/2290
 ZG/ZCG-06-*-22/2290
 ZG/ZCG-10-*-22/2290

**DIMENSIONS IN
 MILLIMETRES (INCHES)**

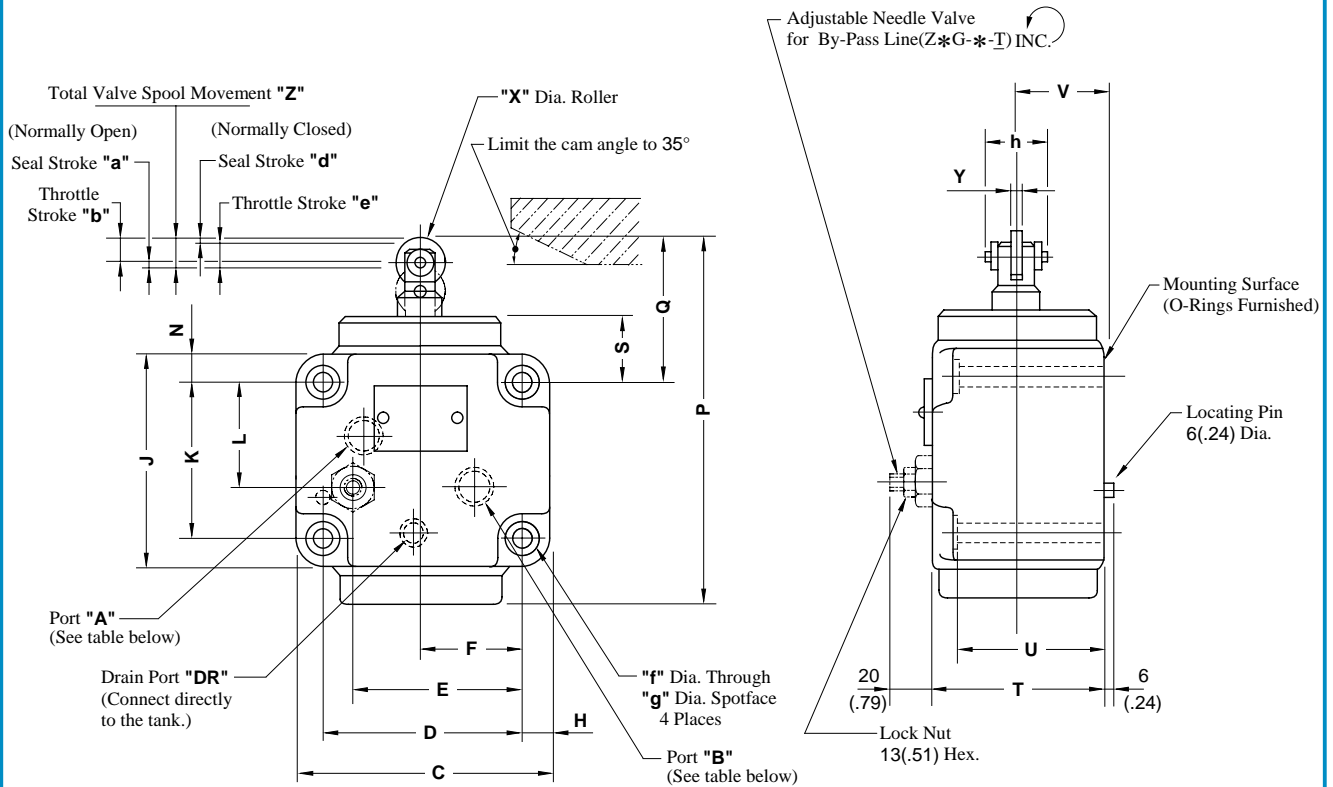

Model Numbers	Port "A"	Port "B"
ZG-*	Controlled flow inlet	Controlled flow outlet
ZCG-*	Controlled flow inlet or Reversed free flow outlet	Controlled flow outlet or Reversed free flow inlet

Model Numbers	Dimensions mm (Inches)												
	C	D	E	F	H	J	K	L	N	P	Q	S	T
ZG/ZCG-03	102 (4.02)	80 (3.15)	66 (2.60)	40 (1.57)	11 (.43)	82 (3.23)	60 (2.36)	41 (1.61)	11 (.43)	141 (5.55)	56 (2.20)	25 (.98)	70 (2.76)
ZG/ZCG-06	120 (4.72)	98 (3.86)	82 (3.23)	49 (1.93)	11 (.43)	106 (4.17)	84 (3.31)	57 (2.24)	11 (.43)	176 (6.93)	65 (2.56)	27 (1.06)	95 (3.74)
ZG/ZCG-10	160 (6.30)	132 (5.20)	103 (4.06)	66 (2.60)	14 (.55)	140 (5.51)	112 (4.41)	75 (2.95)	14 (.55)	224 (8.82)	80 (3.15)	32 (1.26)	110 (4.33)

Model Numbers	Dimensions mm (Inches)											
	U	V	X	Y	Z	a	b	d	e	f	g	h
ZG/ZCG-03	60 (2.36)	35 (1.38)	18 (.71)	6 (.24)	10 (.39)	2 (.08)	8 (.31)	2 (.08)	8 (.31)	8.8 (.35)	14 (.55)	24.5 (.96)
ZG/ZCG-06	85 (3.35)	50 (1.97)	22 (.87)	8 (.31)	13 (.51)	3 (.12)	10 (.39)	3 (.12)	10 (.39)	11 (.43)	17.5 (.69)	29 (1.14)
ZG/ZCG-10	96 (3.78)	55 (2.17)	28 (1.10)	10 (.39)	18 (.71)	3 (.12)	15 (.59)	3 (.12)	15 (.59)	13.5 (.53)	21 (.83)	34 (1.34)

ZGM-03-21/2180/2190
ZGM-06-21/2180/2190
ZGM-10-21/2180/2190

DIMENSIONS IN
MILLIMETRES (INCHES)

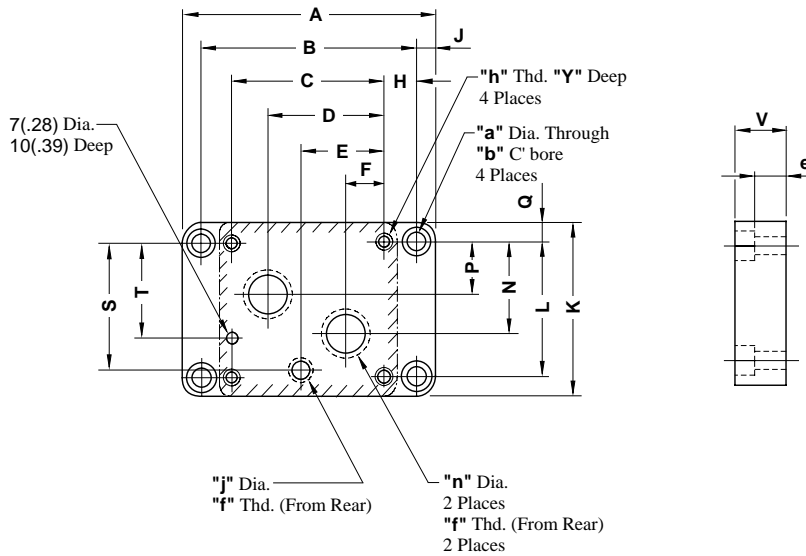
D

Model Numbers	Thd. Size			mm (Inches)		
	"f" Thd.	"g" Thd.	"h" Thd.	j	n	
ZGM-03-21	Rc 3/8	Rc 1/4	M8	6.2 (.24)	14 (.55)	
ZGM-03-2180	3/8 BSP.F	1/4 BSP.F			15 (.59)	
ZGM-03-2190	3/8 NPT	1/4 NPT			5/16-18 UNC	14 (.55)
ZGM-06-21	Rc 3/4	Rc 1/4	M10	6.2 (.24)	23 (.91)	
ZGM-06-2180	3/4 BSP.F	1/4 BSP.F			24.5 (.96)	
ZGM-06-2190	3/4 NPT	1/4 NPT			3/8-16 UNC	23 (.91)
ZGM-10-21	Rc 1-1/4	Rc 1/4	M12	11 (.43)	29 (1.14)	
ZGM-10-2180	1-1/4 BSP.F	1/4 BSP.F				11.7 (.46)
ZGM-10-2190	1-1/4 NPT	1/4 NPT				1/2-13 UNC

Model Numbers	Dimensions mm (Inches)													
	A	B	C	D	E	F	H	J	K	L	N	P	Q	S
ZGM-03	146 (5.75)	124 (4.88)	80 (3.15)	60 (2.36)	42 (1.65)	20 (.79)	22 (.87)	11 (.43)	85 (3.35)	60 (2.36)	40 (1.57)	20 (.79)	12.5 (.49)	58 (2.28)
ZGM-06	160 (6.30)	138 (5.43)	98 (3.86)	74 (2.91)	53 (2.09)	24 (.94)	20 (.79)	11 (.43)	108 (4.25)	84 (3.31)	57 (2.24)	32 (1.26)	12 (.47)	81 (3.19)
ZGM-10	218 (8.58)	190 (7.48)	132 (5.20)	98 (3.86)	70 (2.76)	34 (1.34)	29 (1.14)	14 (.55)	140 (5.51)	112 (4.41)	75 (2.95)	40 (1.57)	14 (.55)	106 (4.17)

Model Numbers	Dimensions mm (Inches)					
	T	V	Y	a	b	e
ZGM-03	44 (1.73)	26 (1.02)	18 (.71)	11 (.43)	17.5 (.69)	15.2 (0.60)
ZGM-06	60 (2.36)	35 (1.38)	18 (.71)	11 (.43)	17.5 (.69)	24.2 (0.95)
ZGM-10	87 (3.43)	45 (1.77)	25 (.98)	14 (.55)	21 (.83)	31.5 (1.24)

Performance Characteristics

Hydraulic Fluid: Viscosity 20 mm²/s (98 SSU) , Specific Gravity 0.850

■ Pressure Drop for Reversed Free Flow

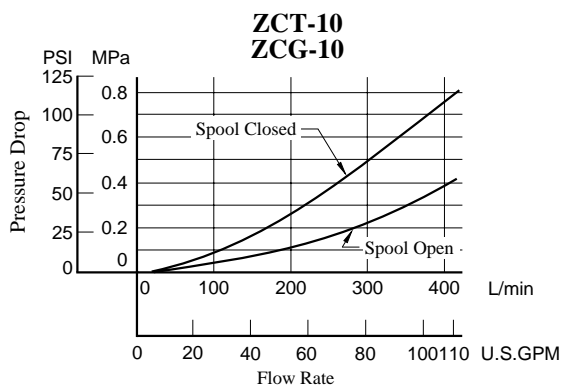
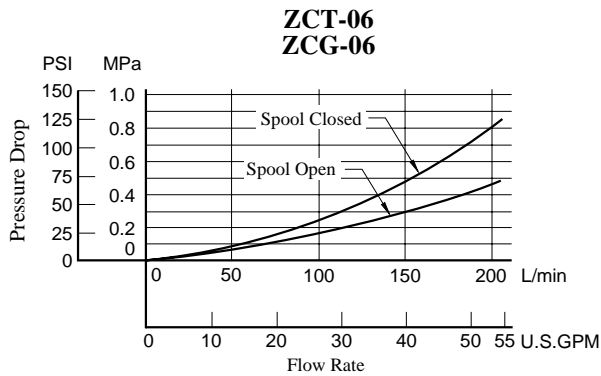
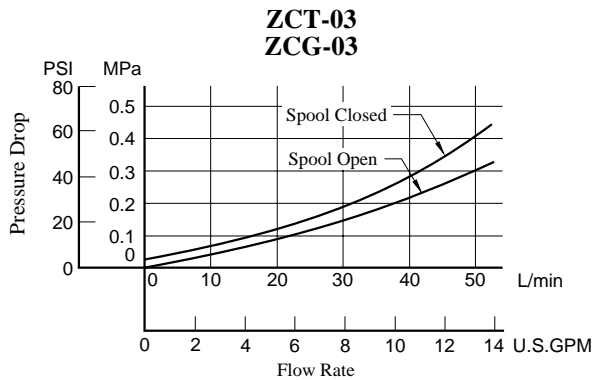

■ Metred Flow vs. Spool Depression

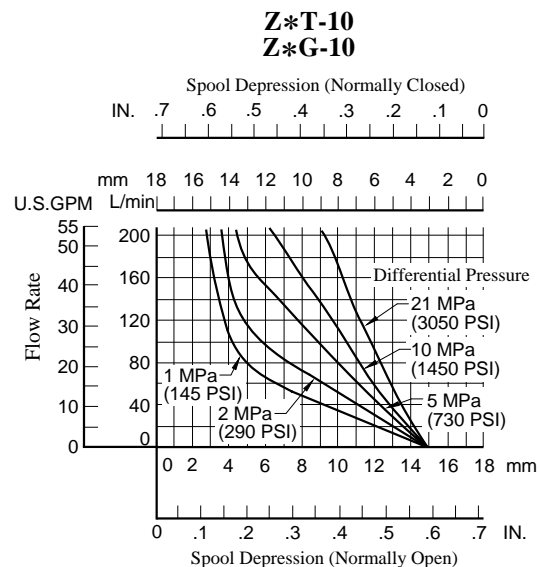
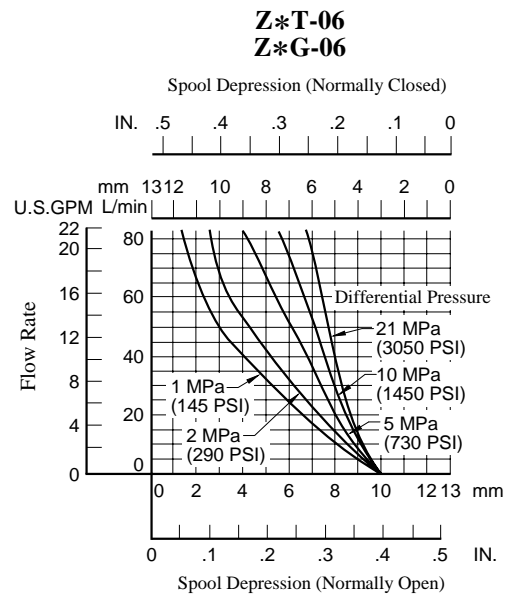
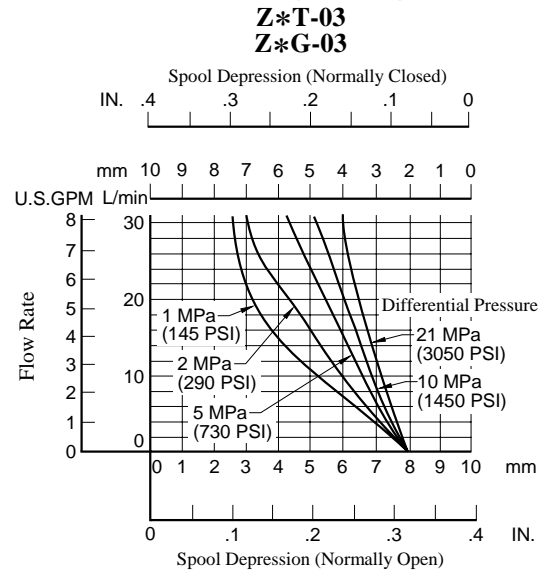

Hydraulic Fluid: Viscosity 20 mm²/s (98 SSU) , Specific Gravity 0.850

■ Metred Flow for Needle Valve

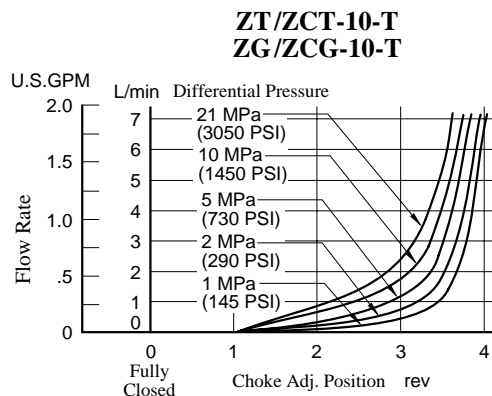
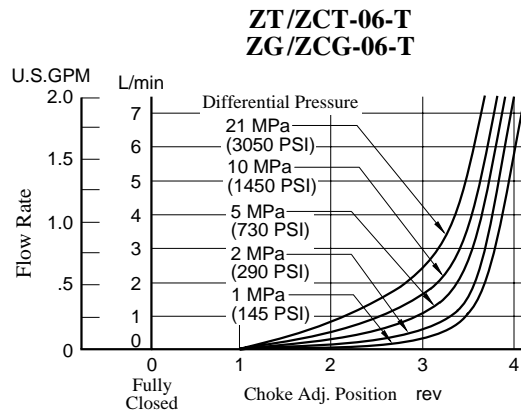
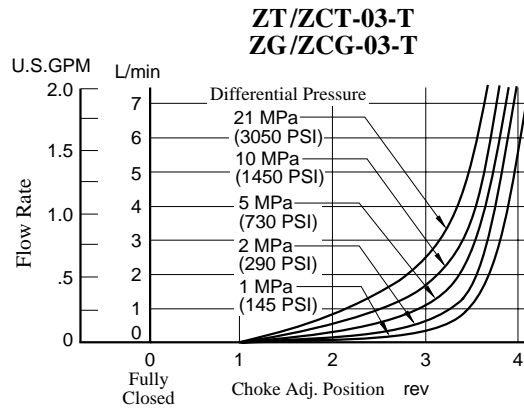

Spare Parts List

ZT/ZCT-03-**-22/2280/2290
ZT/ZCT-06-**-22/2280/2290
ZT/ZCT-10-**-22/2280/2290

CAUTION

When making replacement of seals, please do it carefully after reading through the relevant instructions in the Operator's Manual.

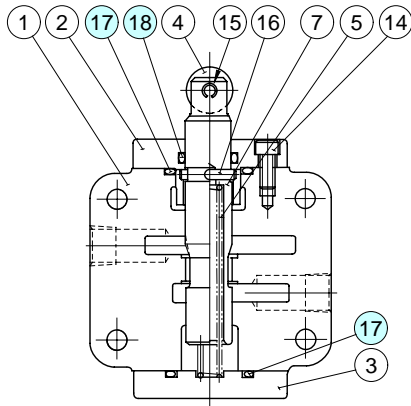

With Check Valve
(ZCT-*)

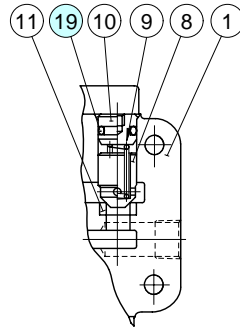

With Adjustable Needle Valve
for By-Pass Line

(ZT
ZCT-*T)

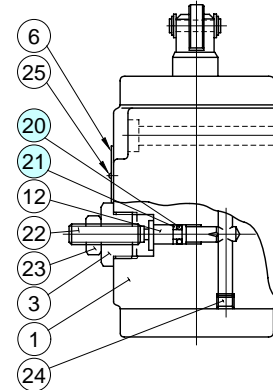

List of Seals

Item	Name of Parts	Part Numbers			Qty.
		ZT ZCT-03	ZT ZCT-06	ZT ZCT-10	
17	O-Ring	SO-NB-P32	SO-NB-P36	SO-NB-P49	2
18	O-Ring	SO-NA-P20	SO-NA-P25	SO-NA-P32	1
19	O-Ring	SO-NB-P12	SO-NB-P18	SO-NB-P22A	1
20	O-Ring	SO-NA-P5	SO-NA-P5	SO-NA-P5	1
21	Back Up Ring	SO-BB-P5	SO-BB-P5	SO-BB-P5	1

Note: When ordering the seals, please specify the seal kit number from the table right.

List of Seal Kits

Model Numbers	Seal Kit Numbers
ZT-03	KS-ZT-03-22
ZT-06	KS-ZT-06-22
ZT-10	KS-ZT-10-22
ZCT-03	KS-ZCT-03-
ZCT-06	22
ZCT-10	KS-ZCT-06-

ZG/ZCG-03-**-22/2290
ZG/ZCG-06-**-22/2290
ZG/ZCG-10-**-22/2290

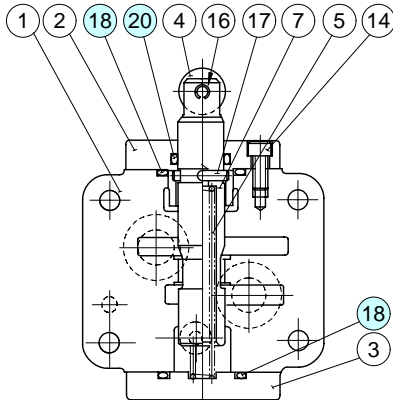

With Check Valve
(ZCG-*)

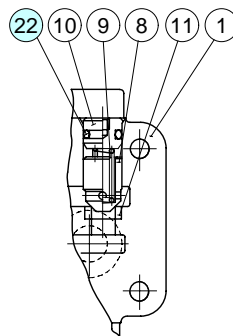

With Adjustable Needle Valve
for By-Pass Line

(ZG
ZCG-*T)

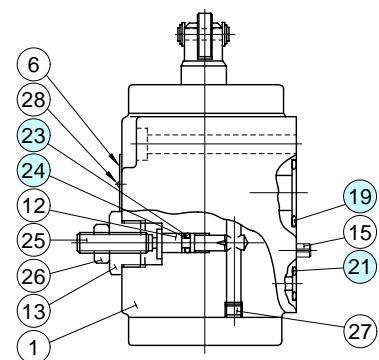

List of Seals

Item	Name of Parts	Part Numbers			Qty.
		ZG ZCG-03	ZG ZCG-06	ZG ZCG-10	
18	O-Ring	SO-NB-P32	SO-NB-P36	SO-NB-P49	2
19	O-Ring	SO-NB-P18	SO-NB-P28	SO-NB-P32	2
20	O-Ring	SO-NA-P20	SO-NA-P25	SO-NA-P32	1
21	O-Ring	SO-NB-P9	SO-NB-P14	SO-NB-P14	1
22	O-Ring	SO-NB-P12	SO-NB-P18	SO-NB-P22A	1
23	O-Ring	SO-NA-P5	SO-NA-P5	SO-NA-P5	1
24	Back Up Ring	SO-BB-P5	SO-BB-P5	SO-BB-P5	1

Note: When ordering the seals, please specify the seal kit number from the table right.

List of Seal Kits

Model Numbers	Seal Kit Numbers
ZG-03	KS-ZG-03-22
ZG-06	KS-ZG-06-22
ZG-10	KS-ZG-10-22
ZCG-03	KS-ZCG-03-22
ZCG-06	KS-ZCG-06-22
ZCG-10	KS-ZCG-10-22



FEED CONTROL VALVES

UCF1G-01 / 03 / 04 (1/8, 3/8, 1/2) UCF2G-03 / 04 (3/8, 1/2) Gasket Mounting

FLOW CONTROLS

Specifications / Model Number Designation

Up to 14 MPa (2030 PSI), 80 L/min (21.1 U.S.GPM)

These valves are the combination of flow control valve, a deceleration valve and a check valve and used mainly for controlling rapid traverse and feed cycles machine tools. Switching from rapid traverse to feed is made by a cam operation, and fine feed control is accomplished by dial rotation regardless of pressure and oil temperature variation. Rapid return is free of cam actuation.

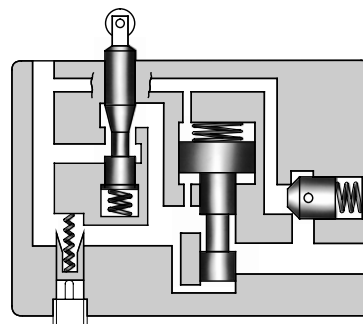

Specifications

Model Numbers	Max. Flow ^{*1} L/min (U.S.GPM)	Metred Flow Range L/min (U.S.GPM)		Max. Reversed Free Flow L/min (U.S.GPM)	Max. Operating Pressure MPa (PSI)	Approx. Mass kg (lbs.)
		Feed	Fine Feed			
UCF1G-01-4-A*-11*	16 [12] (4.2 [3.2])	0.03-4 (.008-1.06)	—	20 (5.3)	14 (2030)	1.6 (3.5)
UCF1G-01-4-B*-11*	12 [8] (3.2 [2.1])					
UCF1G-01-4-C*-11*	8 [4] (2.1 [1.06])					
UCF1G-01-8-A*-11*	20 [12] (5.3 [3.2])	0.03-8 (.008-2.1)	—	40 (10.6)	14 (2030)	2.6 (5.7)
UCF1G-01-8-B*-11*	16 [8] (4.2 [2.1])					
UCF1G-01-8-C*-11*	12 [4] (3.2 [1.06])					
UCF1G-03-4*-10*	40 [40] (10.6 [10.6])	0.05-4 (.013-1.06)	—	40 (10.6)	14 (2030)	2.6 (5.7)
UCF1G-03-8*-10*		0.05-8 (.013-2.1)	—			
UCF2G-03-4*-10*	40 [40] (10.6 [10.6])	0.1-4 (.026-1.06)	0.05-4 (.013-1.06)	40 (10.6)	14 (2030)	2.7 (6.0)
UCF2G-03-8*-10*		0.1-8 (.026-2.1)	0.05-4 (.013-1.06)			
UCF1G-04-30-30*	80 [40] (21.1 [10.6])	0.1-22 (.026-5.8)	—	80 (21.1)	14 (2030)	6.5 (14.3)
UCF2G-04-30-30*		0.1-22 (.026-5.8)	0.1-17 (.026-4.5)			9.2 (20.3)

★ 1. The maximum flow rates are values with the deceleration valve and the flow control valve fully open. The values in [] are maximum flow rates with the deceleration valve fully open and the flow control valve fully closed.

★ 2. The values in [] are for pressures above 7 MPa (1020 PSI).

Model Number Designation

F-	UCF1	G	-01	-4	-A	-E	-11	*
Special Seals	Series Number	Type of Mounting	Valve Size	Nominal Metred Flow L/min (U.S.GPM)	Deceleration Valve Max. Flow L/min (U.S.GPM)	Drain Connection	Design Number	Design Standards
F-: Special Seals for Phosphate Ester Type Fluids (Omit if not required)	UCF1: Single Feed Control	G: Gasket Mounting	01	4: 4 (1.06) 8: 8 (2.1)	A: 12 (3.2) B: 8 (2.1) C: 4 (1.06)	None: Internal Drain E: External Drain	11	Refer to ★ 1
			03	4: 4 (1.06) 8: 8 (2.1)	—	10		
			04	30:30 (7.9)	—	30		
	UCF2: Double Feed Control	G: Gasket Mounting	03	4: 4 (1.06) 8: 8 (2.1)	—	None: Internal Drain E: External Drain	10	
04	30:30 (7.9)		—	None: External Drain	30			

★ 1. Design Standards: None.....Japanese Standard "JIS" and European Design Standard 90N. American Design Standard

Graphic Symbols

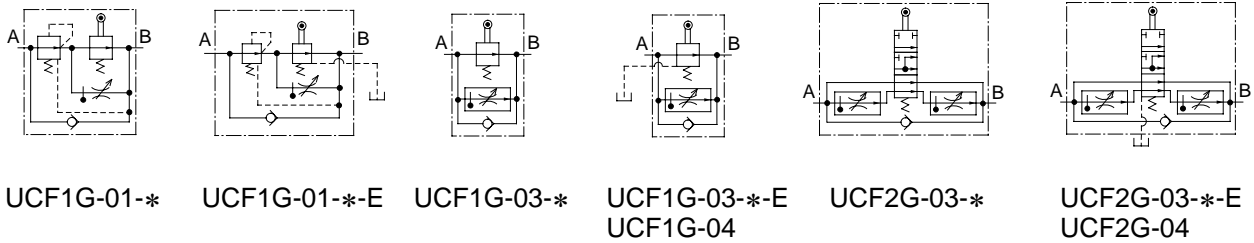

Hydraulic Fluids

Fluid Types

Any type of hydraulic fluids listed in the table below can be used.

Petroleum base oils	Use fluids equivalent to ISO VG 32 or VG 46.
Synthetic fluids	Use phosphate ester or polyol ester fluid. When phosphate ester fluid is used, prefix "F-" to the model number because the special seals (fluororubber) are required to be used.
Water containing fluids	Use water-glycol fluid.

Note: For use with hydraulic fluids other than those listed above, please consult your Yuken representatives in advance.

Recommended Viscosity and Oil Temperatures

Viscosity ranging between 15 - 400 mm²/s (77 - 1800 SSU).

Oil temperatures between -15/+70°C (5 - 158°F).

Use hydraulic fluids which satisfy the recommended viscosity and oil temperatures given above.

Control of Contamination

Due caution must be paid to maintaining control over contamination of the hydraulic fluids which may otherwise lead to breakdowns and shorten the life of the valves. Please maintain the degree of contamination within NAS 1638-Grade 12. Use 25 μm or finer line filter.

Attachment

Mounting Bolts

Valve Model Numbers	Socket Head Cap Screw		Qty.
	Japanese Std. "JIS" & European Design Std.	N. American Design Std.	
UCF1G-01	M6 × 55 Lg.	1/4-20 UNC × 2-1/4 Lg.	4
UCF1G-03	M6 × 55 Lg.	1/4-20 UNC × 2-1/4 Lg.	4
UCF2G-03	M6 × 55 Lg.	1/4-20 UNC × 2-1/4 Lg.	4
UCF1G-04	M10 × 70 Lg.	3/8-16 UNC × 2-3/4 Lg.	4
UCF2G-04	M10 × 70 Lg.	3/8-16 UNC × 2-3/4 Lg.	4

■ Instructions

● Allowable pressures at controlled flow outlet

If internal drain types of UCF1G-01 or 03 or UCF2G-03 are used, use them in metre-out circuits in order to limit the valve outlet pressure to the valves shown below. In addition, external drain types can also be used in metre-in circuits.

Model Numbers		Allowable Outlet Port Back Pres. MPa (PSI)
Internal Drain Type	UCF1G-01- UCF1G-03- UCF2G-03-	0.3 (44)
External Drain Type	UCF1G-01- UCF1G-03- UCF1G-04 UCF2G-03- UCF2G-04	14 (2030)

● Minimum required pressure difference

The minimum pressure differential between inlet and outlet port is required to obtain the optimum pressure compensation. It varies accordingly to the flow rate to be set. For details, refer to the performance curve.

● Spool push down level

Limit the spool push down level within the allowable maximum stroke range shown in the installation drawings.

● Allowable drain port back pressure

Limit to 0.1 MPa (15 PSI).

In addition, connect the drain pipe independently and directly to the tank. (This applies only to external drain types.)

● Required Force for Spool Push Down

Model Numbers	Drain Type	Force N (lbs.)
UCF1G-01	Internal drain type	100 (22.5)
	External drain type	80 (18.0)
UCF1G-03	Internal drain type	170 (38.2)
	External drain type	90 (20.2)
UCF2G-03	Internal drain type	170 (38.2)
	External drain type	130 (29.2)
UCF1G-04	External drain type	170 (38.2)
UCF2G-04	External drain type	170 (38.2)

Note: The push down forces are with the maximum allowable pressure at the port concerned, which is controlled flow outlet "B" for internal drain types or the drain port for internal drain types.

● Line filter

To carry out flow adjustments by as small degree as 2 L/min (.53 U.S. GPM) or less, be sure to use a line filter, 10 or less, near the valve inlet.

● Flow adjustment

[UCF1G-01, UCF*G-03]

Loosen the locking screw and turn the flow adjustment dial clockwise for increase, and anti-clockwise for decrease.

The dial makes about 4 revolutions from zero to full flow and the valve opening is indicated on the revolution indicator.

After flow adjustment, tighten the locking screw.

[UCF*G-04]

Loosen the locking screw and turn the flow adjustment handle clockwise to increase, and anti-clockwise to decrease.

Open condition is indicated in digital-scale in built-in revolution indicator.

After flow adjustment, tighten the locking screw.



■ Min. Required Pressure Difference

UCF1G-01

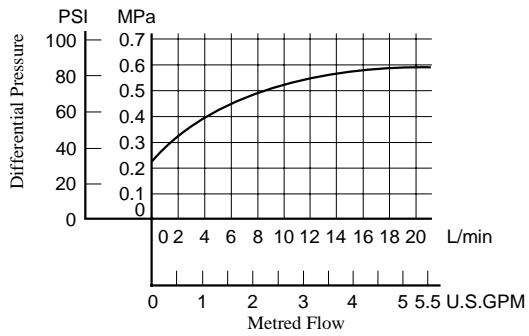

UCF1G-03

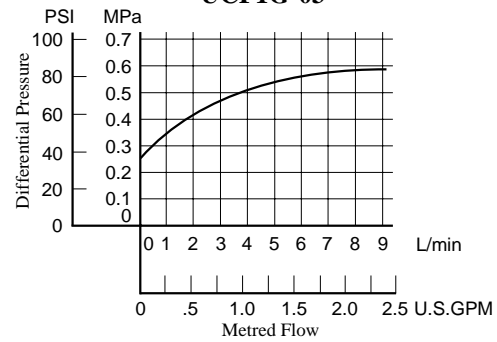

UCF2G-03

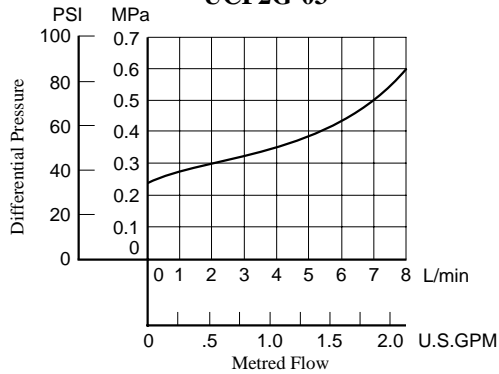

**UCF1G-04
UCF2G-04**

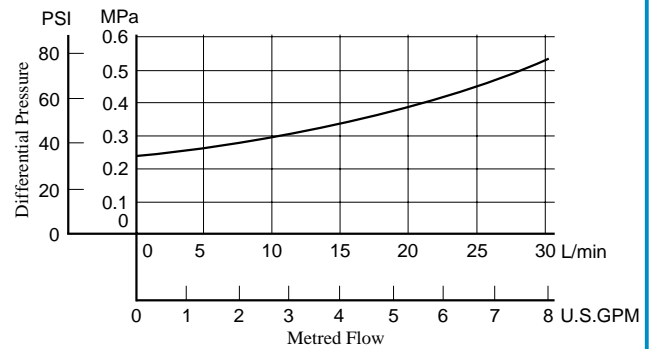

UCF1G-01-***-11/1190

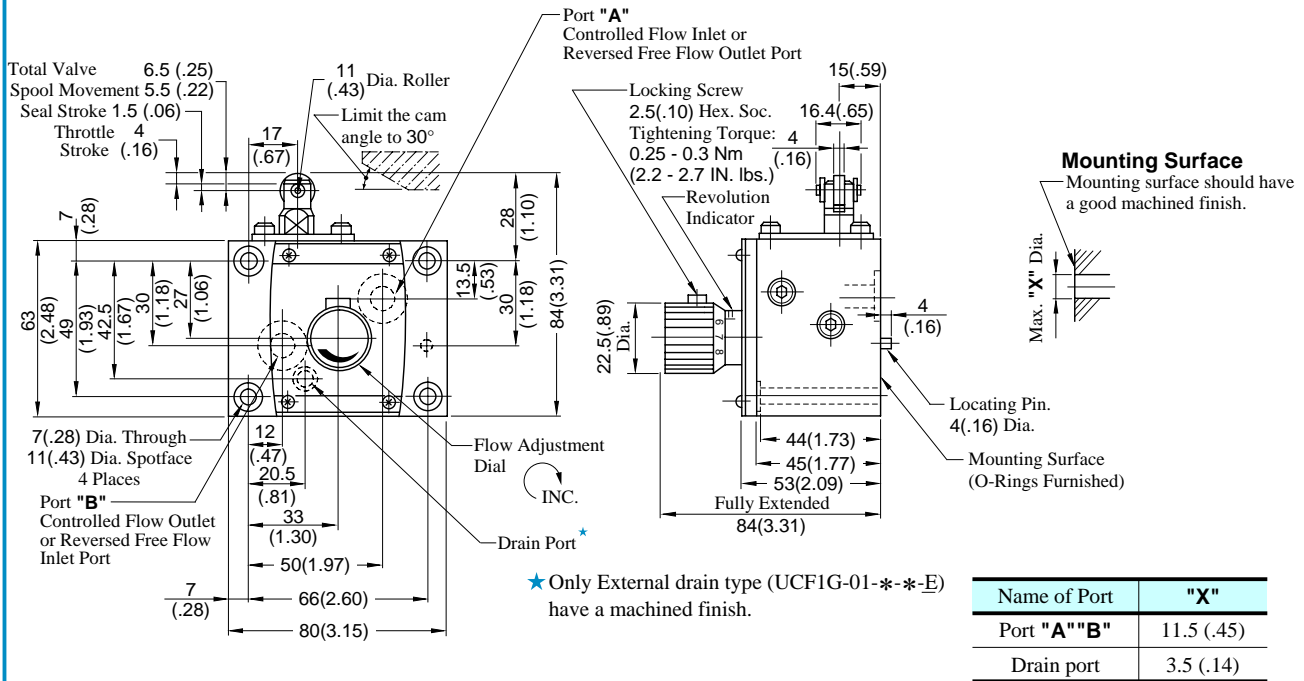

DIMENSIONS IN
MILLIMETRES (INCHES)

UCF1G-03-***-10/1090

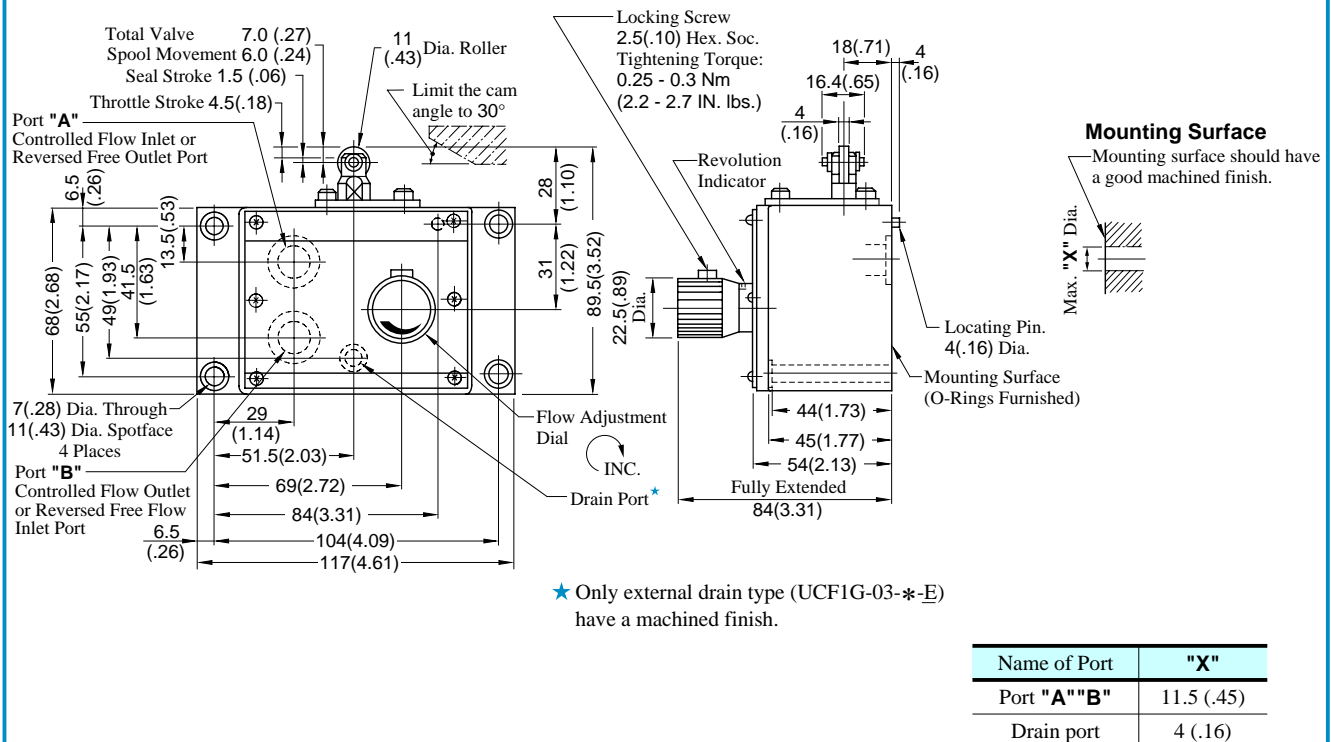

UCF2G-04-30-30/3090

**DIMENSIONS IN
MILLIMETRES (INCHES)**

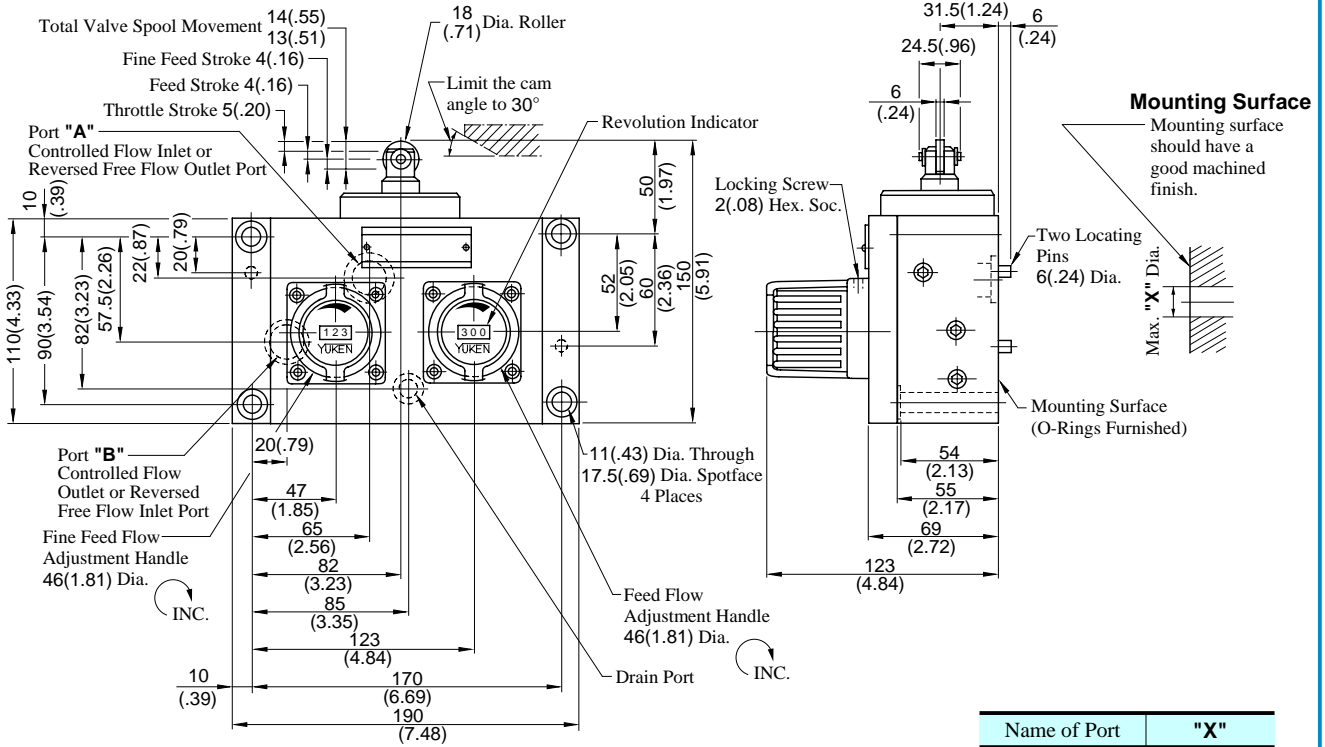

Name of Port	"X"
Port "A"	18 (.71)
Port "B"	15.5 (.61)
Drain port	8.5 (.33)



UCF1G-01-**-**-11/1190

⚠ CAUTION

When making replacement of seals, please do it carefully after reading through the relevant instructions in the Operator's Manual.

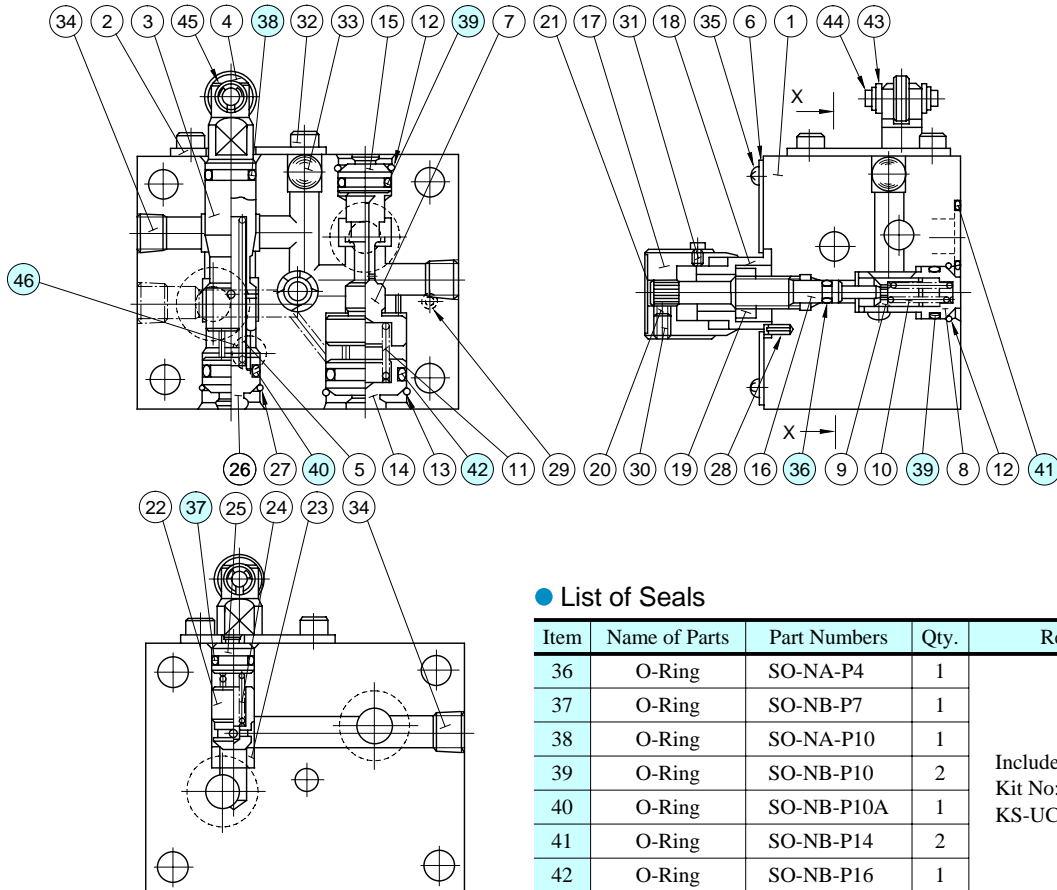

Section
X-X

● List of Seals

Item	Name of Parts	Part Numbers	Qty.	Remarks
36	O-Ring	SO-NA-P4	1	Included in Seal Kit Kit No: KS-UCF1G-01-11
37	O-Ring	SO-NB-P7	1	
38	O-Ring	SO-NA-P10	1	
39	O-Ring	SO-NB-P10	2	
40	O-Ring	SO-NB-P10A	1	
41	O-Ring	SO-NB-P14	2	
42	O-Ring	SO-NB-P16	1	
46	O-Ring	SO-NB-P5	1*	

★ Used only for external drain types (UCF1G-01-**-**-E-11).

UCF1G-03-*-**-10/1090

⚠ CAUTION

When making replacement of seals, please do it carefully after reading through the relevant instructions in the Operator's Manual.

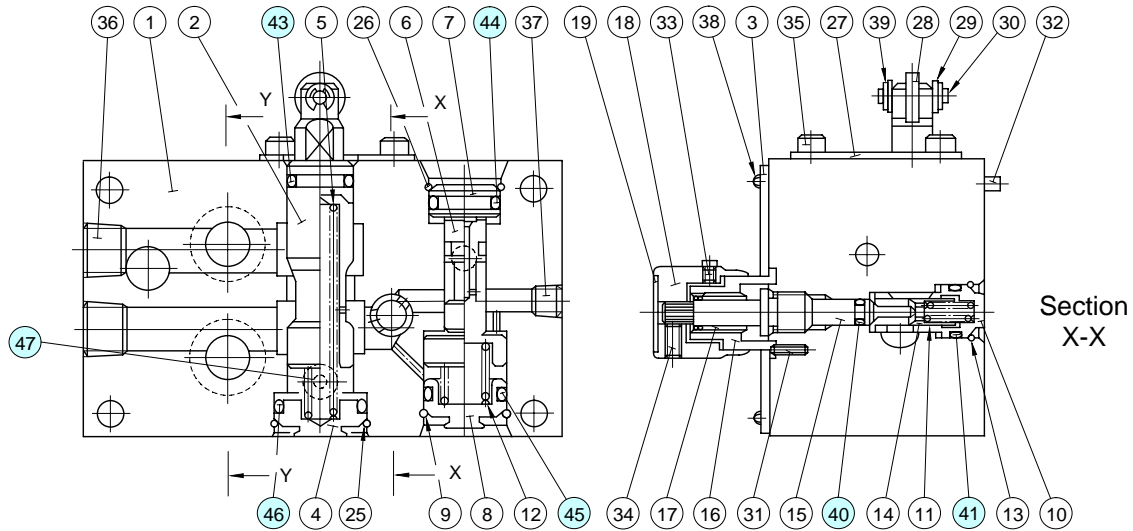

● List of Seals

Item	Name of Parts	Part Numbers	Qty.	Remarks
40	O-Ring	SO-NA-P4	1	Included in Seal Kit Kit No: KS-UCF1G-03-10
41	O-Ring	SO-NB-P10	1	
42	O-Ring	SO-NB-P10A	1	
43	O-Ring	SO-NA-P12	1	
44	O-Ring	SO-NB-P14	3	
45	O-Ring	SO-NB-P16	1	
46	O-Ring	SO-NB-P18	1	
47	O-Ring	SO-NA-P6	1*	

★ Used only for external drain types (UCF1G-03-*-E-10).

UCF2G-03-*-**-10/1090

CAUTION

When making replacement of seals, please do it carefully after reading through the relevant instructions in the Operator's Manual.

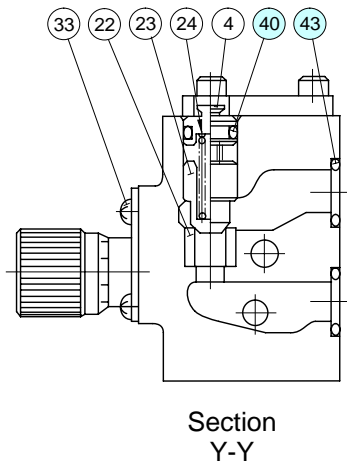
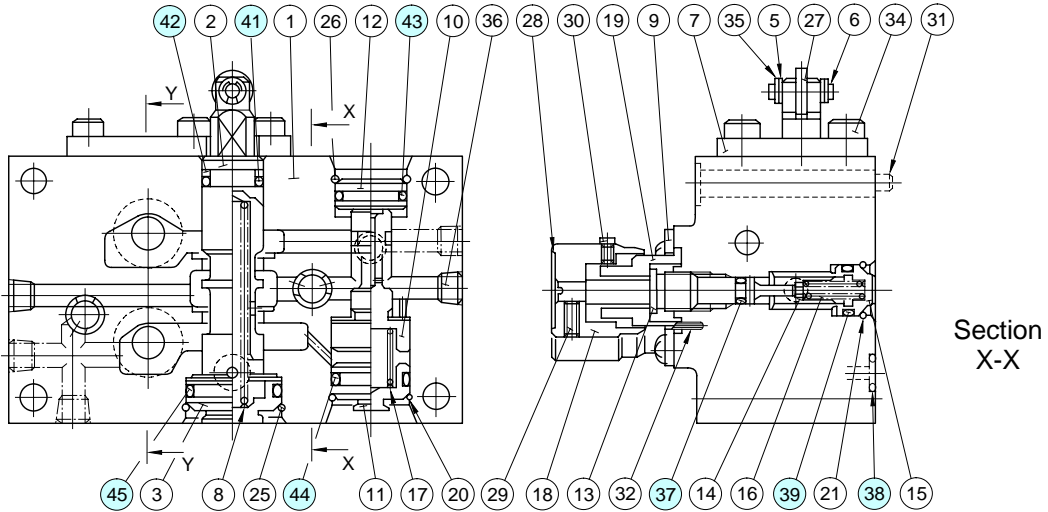

● List of Seals

Item	Name of Parts	Part Numbers	Qty.
37	O-Ring	SO-NA-P4	2
38	O-Ring	SO-NB-P6	1 ^{★1}
39	O-Ring	SO-NB-P10	2
40	O-Ring	SO-NB-P10A	1
41	O-Ring	SO-NA-P12	1
42	Back Up Ring	SO-BB-P12	1 ^{★2}
43	O-Ring	SO-NB-P14	3
44	O-Ring	SO-NB-P16	1
45	O-Ring	SO-NB-P21	1

★ 1. Used only for external drain types (UCF2G-03-*-E-10*).

★ 2. Used only for internal drain types (UCF2G-03-*-10*).

Note: When ordering the seals, please specify the seal kit number from the table left.

● List of Seal Kits

Model Numbers	Seal Kit Numbers
UCF2G-03-*-10*	KS-UCF2G-03-10
UCF2G-03-*-E-10*	KS-UCF2G-03-E-10

UCF1G-04-30-30/3090

UCF2G-04-30-30/3090



CAUTION

When making replacement of seals, please do it carefully after reading through the relevant instructions in the Operator's Manual.

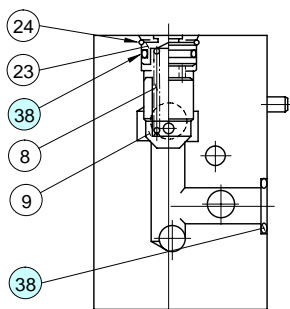
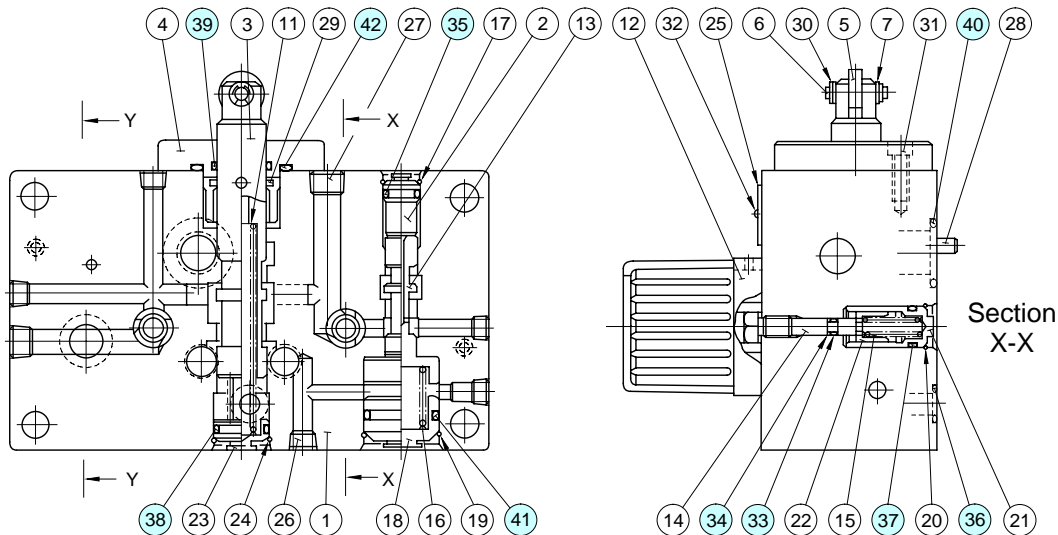

Section Y-Y

List of Seals

Item	Name of Parts	Part Numbers	Quantity	
			UCF1G	UCF2G
33	O-Ring	SO-NA-P4	1	2
34	Back Up Ring	SO-BB-P4	1	2
35	O-Ring	SO-NB-P14	1	—
		SO-NB-P10A	—	1
36	O-Ring	SO-NB-P11	1	1
37	O-Ring	SO-NB-P12	1	2
38	O-Ring	SO-NB-P18	3	3
39	O-Ring	SO-NA-P20	1	1
40	O-Ring	SO-NB-P18	1	—
		SO-NB-P22A	—	1
41	O-Ring	SO-NB-G25	1	1
42	O-Ring	SO-NB-P34	1	1

List of Seal Kits

Model Numbers	Seal Kit Numbers
UCF1G-04	KS-UCF1G-04-30
UCF2G-04	KS-UCF2G-04-30

Note: When ordering the seals, please specify the seal kit number from the table left.





NEEDLE VALVES

GCT -02 (1/4) GCTR

Threaded Connections

FLOW
CONTROLS

Specifications/Model Number Designation/Hydraulic Fluids

Up to 35 MPa (5080 PSI)

Used as stop valves for pressure gauge lines and small-capacity line. Also can be used as restrictors for regulating flow rates in pilot lines.



Specifications

Model Numbers		Max. Flow L/min (U.S.GPM)	Max. Operating Pressure MPa (PSI)	Approx. Mass kg (lbs.)
In-Line Type	Angle Type			
GCT-02-32*	GCTR-02-32*	★	35 (5080)	0.34 (.75)

★ Depends on allowable pressure drops. See flow vs. adjustment revolutions characteristics and pressure drop at full open characteristics.

Model Number Designation

F-	GCT	-02	-32	*
Special Seals	Series Number	Valve Size	Design Number	Design Standards
F: Special Seals for Phosphate Ester Type Fluids (Omit if not required)	GCT : In-line Type Needle Valve, Threaded Connection GCTR : Angle Type Needle Valve, Threaded Connection	02	32	Refer to ★

Graphic Symbol



★ Design Standards: None.....Japanese Standard "JIS"
80.....European Design Standard
90.....N. American Design Standard

Hydraulic Fluids

Fluid Types

Any type of hydraulic fluids listed in the table below can be used.

Petroleum base oils	Use fluids equivalent to ISO VG32 or VG46.
Synthetic fluids	Use phosphate ester or polyol ester fluid. When phosphate ester fluid is used, prefix "F-" to the model number because the special seals (fluororubber) are required to be used.
Water containing fluids	Use water-glycol fluid.

Note: For use with hydraulic fluids other than those listed above, please consult your Yuken representatives in advance.

Recommended Viscosity and Oil Temperatures

Viscosity ranging between 15 - 400 mm²/s (77 - 1800 SSU).

Oil temperatures between -15/+70°C (5 - 158°F).

Use hydraulic fluids which satisfy the recommended viscosity and oil temperatures given above.

Control of Contamination

Due caution must be paid to maintaining control over contamination of the hydraulic fluids which may otherwise lead to breakdowns and shorten the life of the valves. Please maintain the degree of contamination within NAS 1638-Grade 12. Use 25 μm or finer line filter.