

SILVER LITE

**LIGHTWEIGHT ALUMINUM
HYDRAULIC EQUIPMENT**





**RAS-SERIES
SPRING RETURN ALUMINUM CYLINDERS
30 THROUGH 150 TONS
PAGE 3**



**RAL-SERIES
SPRING RETURN LOCKNUT ALUMINUM
CYLINDERS
30 THROUGH 150 TONS
PAGE 4**



**RAC & RACD-SERIES
CENTER HOLE ALUMINUM CYLINDERS
30 & 60 SINGLE ACTING SPRING RETURN
30 THROUGH 150 TON DOUBLE ACTING
PAGE 5**



**P-SERIES
ALUMINUM HAND PUMPS
30 & 70 cu. in. CAPACITY
PAGE 6**



**STL-SERIES
PUMP & CYLINDER SETS
30 THROUGH 100 TONS CYLINDERS
30 & 60 TON CENTER HOLE CYLINDERS
PAGE 7**

30 - 150 TON ALUMINUM CYLINDERS

RAC SERIES



Up to 60%
Lighter Than
Steel Cylinders.

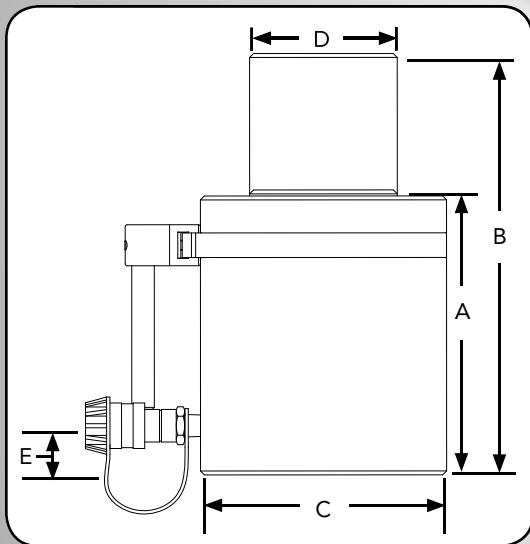

- 13 standard models from 30 through 150 tons.
- Heavy duty spring for fast & full retraction.
- Large bearing surfaces for side load protection.
- Carrying handles standard on all models.
- Hard anodized coating reduces wear & corrosion.
- Stop rings for piston blow-out protection.
- Rod wiper protects inner cylinder from dirt.
- High flow quality couplers.
- Complies with ANSI/ASME B30.1 safety standards.

Aluminum Spring Return Cylinders 30 Through 150 Ton Capacities											
Model Number	Cap. (tons)	Stroke (in)	A Min. Ht. (in)	B Ext. Ht. (in)	Effect Area (sq. in)	Oil Cap. Req'd (cu in)	C Body O.D. (in)	D Piston O.D. (in)	E Base to Port C/L (in)	Wgt. (lbs)	Suggstd. Hand Pump
RAS302B	30	2	6 1/2	8 1/2	6.5	13	4 1/2	2 1/2	1 1/2	14	P42/P72
RAS306B		6	10 1/2	16 1/2		39				18	P72/P82
RAS502B	50	2	6 1/2	8 1/2	11	22.1	5 1/2	3 1/8		13	P72/P82
RAS504B		4	8 1/2	12 1/2		44.2				17	P72/P82
RAS506B		6	10 1/2	16 1/2		66.2				28	P140
RAS5010B		10	14 1/2	24 1/2		110.4				36	*
RAS1002B	100	2	6 1/2	8 1/2	20.7	41.2	8	4 1/4		40	P72/P82
RAS1004B		4	8 1/2	12 1/2		83.4				45	P140
RAS1006B		6	10 1/2	16 1/2		123.7				50	*
RAS10010B		10	14 1/2	24 1/2		206				68	*
RAS1502B	150	2	6 1/2	8 1/2	30.7	61.4	10	4 7/8	58	P140	
RAS1506B		6	10 1/2	16 1/2		184.1			86	*	
RAS15010B		10	14 1/2	24 1/2		306.8			110	*	

* Power pumps are suggested for these units.

Up to 60%
Lighter Than
Steel Cylinders.

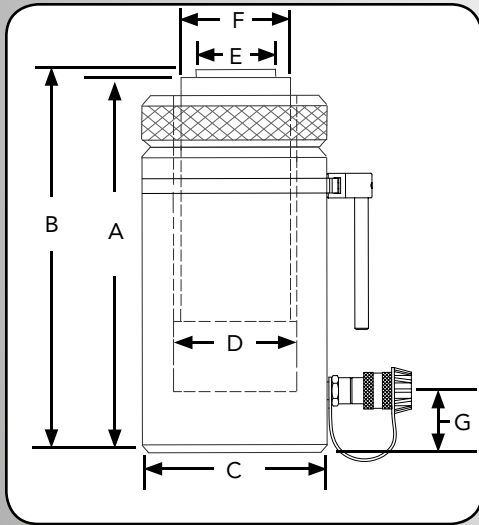

- 11 standard models from 50 through 150 tons.
- Locknuts for extended load holding.
- Large bearing surfaces for side load protection.
- Hard anodized coating reduces wear & corrosion.
- Carrying handles standard on all models.
- Rod wiper protects inner cylinder from dirt.
- Stop rings for piston blow-out protection.
- Heavy duty spring for fast & full retraction.
- High flow quality couplers.
- Complies with ANSI/ASME B30.1 safety standards.

Aluminum Spring Return Locknut Cylinders 50 Through 150 Ton Capacities

Model Number	Cap. (tons)	Stroke (in)	A Min. Ht. (in)	B Ext. Ht. (in)	Effect Area (sq. in)	Oil Cap. Req'd (cu in)	C Body O.D. (in)	D Cyl. Bore Dia. (in)	E Saddle Dia. (in)	F Piston O.D. (in)	G Base to Port C/L (in)	Wgt. (lbs)	Suggstd. Hand Pump
RAL502	50	2	8 1/8	10 1/8	11.04	21.65	5 1/2	3 3/4	2 1/2	3 1/8	1 1/2	22	P42/P72
RAL504		4	10 1/8	14 1/8		43.3						38	P72/P82
RAL506		6	12 1/8	18 1/8		64.92						32	P72/P82
RAL5010		10	16 1/8	26 1/8		108.2						40	P140
RAL1002	100	2	8 3/8	10 3/8	20.68	40.51	8	5 1/8	3 1/2	4 1/4	1 1/2	45	P72/P82
RAL1004		4	10 3/8	14 3/8		81						55	P82
RAL1006		6	12 3/8	18 3/8		121.5						64	P140
RAL10010		10	16 3/8	26 3/8		202.5						82	*
RAL1502	150	2	8 3/8	10 3/8	30.68	60	10	6 1/4	4 1/2	5	1 1/2	65	P140
RAL1506		6	12 3/8	18 3/8		181.8						101	*
RAL15010		10	16 3/8	26 3/8		303						156	*

CENTER HOLE ALUMINUM CYLINDER

RAC & RACD SERIES

**Up to 60%
Lighter Than
Steel Cylinders.**



- 4 standard single-acting models in 30 and 60 tons.
- 14 standard double-acting models in 30 thru 150 tons.
- Chrome plated center sleeve for extra protection against wear & corrosion.
- Heavy duty spring for fast & full retraction.
- Hard anodized coating reduces wear & corrosion.
- Carrying handles standard on all models.
- Steel base & piston for protection against load damage.
- Large bearing surfaces for side load protection.
- Rod wiper protects inner cylinder from dirt.
- Complies with ANSI/ASME B30.1 safety standards.

Aluminum Spring Return Single Acting Center Hole Cylinders 30 & 60 Ton Capacities

Model Number	Cap. (tons)	Stroke (in)	A Min. Ht. (in)	B Ext. Ht. (in)	C Center Hole Dia. (in)	Effect Area (sq. in)	Oil Cap. Req'd (cu in)		D Body O.D. (in)	E Base to Port C/L (in)	Wgt. (lbs)	Suggstd. Hand Pump
							Push	Pull				
RAC303	30	3	8 3/4	11 3/4	1 3/16	7.21	22	5 1/2	1	22	P42/P72	
RAC306		6	11 3/4	17 3/4			44			30		
RAC603	60	3	10 1/8	13 1/8	2 1/8	12.3	37	7 1/2	1	42	P72/P82	
RAC606		6	13 1/4	19 1/4			74			55		P140

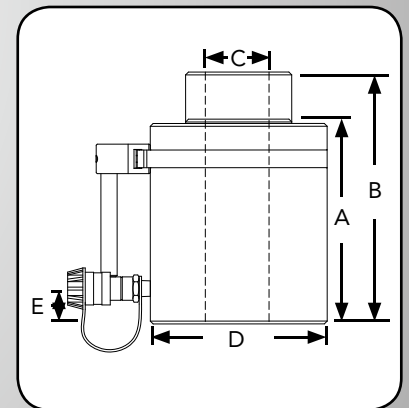

Aluminum Double Acting Center Hole Cylinders 30 & 150 Ton Capacities

Model Number	Cap. (tons)	Stroke (in)	A Min. Ht. (in)	B Ext. Ht. (in)	C Center Hole Dia. (in)	Effect Area		Oil Cap. Req'd		D Body O.D. (in)	E Base to Port C/L (in)	F Collar to Port C/L (in)	Wgt. (lbs)	Suggstd. Hand Pump
						Push (sq. in)	Pull (sq. in)	Push (cu. in)	Pull (cu. in)					
RACD302	30	2	7	9	1 1/2	6.35	3.25	14.34	6.50	5	1 3/4	1 3/4	20	P140D
RACD306		6	11	17				43.02	19.50				28	
RACD3010		10	15	25				71.70	32.50				35	
RACD502	50	2	7	9	2 1/8	10.30	3.43	21.71	6.86	8	1 3/4	1 3/4	33	P140D
RACD504		4	9	13				43.44	13.72				41	
RACD506		6	11	17				65.16	20.58				49	
RACD5010		10	15	25				108.60	34.30				65	
RACD1002	100	2	10	12	3 1/2	20.28	7.8	41.52	15.60	11	2 1/2	2 1/2	85	P140D
RACD1004		4	12	16				83.04	31.20				93	
RACD1006		6	14	20				124.56	46.80				102	
RACD10010		10	18	28				206.60	78.00				132	
RACD1502	150	2	10	12	3 1/2	31.47	9	61.26	17.96	12	2 1/2	2 1/2	109	P140D
RACD1506		6	14	20				183.73	53.98				132	
RACD15010		10	18	28				306.30	89.82				156	

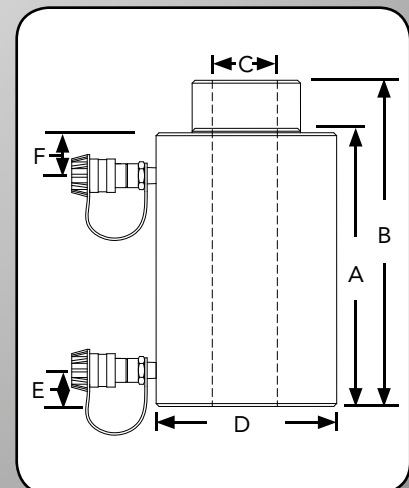

* Power pumps are suggested for these units.



- 5 standard models in 30 and 70 cu. in. reservoirs.
- Weighing just 9 lbs with a full 70 cu. in. of usable oil gives the P71 & P72 the highest available capacity at the least amount of weight.
- P30 is ideal for low pressure application when a small light weight pump is required.
- Carrying handles standard on all models.
- 25% faster per stroke than comparable pumps equals less work for the operator.
- Low handle efforts means less strain for the operator.
- All alloy construction resists corrosion.
- All Silver Lite pumps stand up to heat, welding sparks, and other harsh environments.
- Complies with ANSI/ASME B30.1 safety standards.

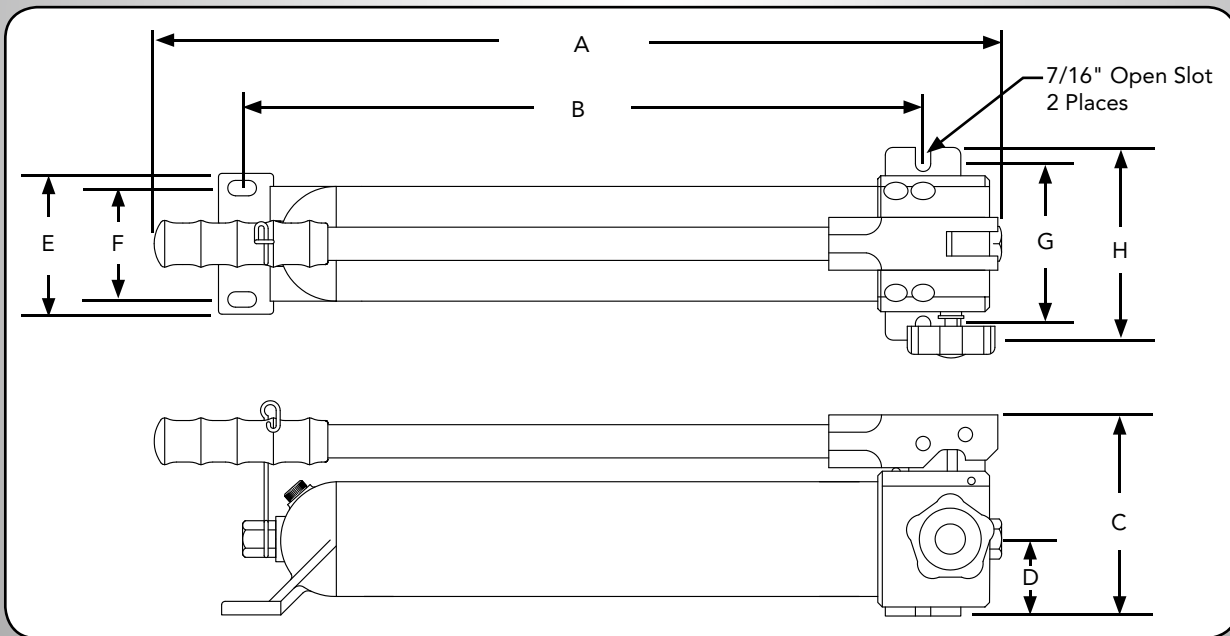

Light Weight Aluminum Hand Pumps for Single-Acting Cylinders & Tools

Model Number	Speed	Pressure Rating (PSI)		Oil Volume Per Stroke (cu. in.)		Usable Oil Capacity (cu. in.)	A (in)	B (in)	C (in)	D (in)	E (in)	F (in)	G (in)	H (in)	Weight (lbs)
		1st Stage	2nd Stage	1st Stage	2nd Stage										
P30	2	200	3,000	.91	.19	30	16.46	11.81							8
P32		200	10,000	.82	.16										
P71	1	10,000		.19		70	24.09	19.44	5.55	2.00	4.41	3.19	4.56	5.50	9
P71V															
P72	2	200	10,000	.91	.19										

SILVER LITE HAND PUMP & CYLINDER SETS



- Maximum versatility with a wide variety of cylinders.
- Optimal performance is provided with matched hand pump & cylinders.
- Use cylinders in upright, inverted or horizontal position.
- Maximum control & safety is provided with the pressure gauge included.
- Heavy duty spring for fast & full cylinder retraction.
- High flow quality couplers.
- Complies with ANSI/ASME B30.1 safety standards.

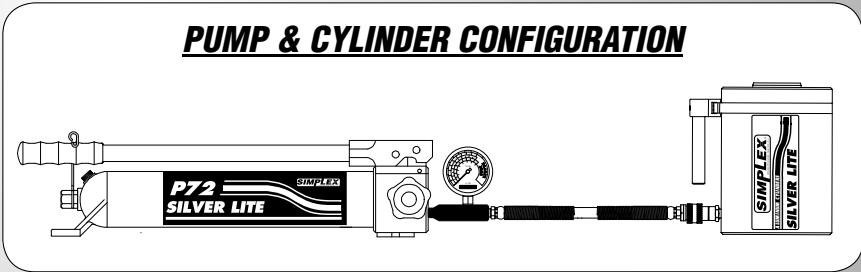

Aluminum Spring Return Single Acting Sets								
Model Number	Cap. (tons)	Stroke (in)	Closed Height (in)	Cylinder Model	Pump Model	Hose Model	Gauge Model	Gauge Adapter
STL302	30	2	6 1/2	RAS302B	P72	HC6	G5	GA1
STL306		6	10 1/2	RAS306B				
STL502	50	2	6 1/2	RAS502B				
STL504		4	8 1/2	RAS504B				
STL1002	100	2	8 1/2	RAS1002B				

Aluminum Spring Return Single Acting Center Hole Sets									
Model Number	Cap. (tons)	Stroke (in)	Closed Height (in)	Center Hole Dia. (in)	Cylinder Model	Pump Model	Hose Model	Gauge Model	Gauge Adapter
STL303HC	30	3	11 3/4	1 3/16	RAC306	P72	HC6	G5	GA1
STL306HC		6	17 3/4		RAC306				
STL603HC	60	3	13 1/8	2 1/8	RAC603				

SIMPLEX OFFICES

UNITED STATES HOME
OFFICE AND FACTORY
2525 Gardner Road
Broadview, IL 60155-3719
Phone: (708) 865-1500
Fax: (708) 865-0894
Toll Free: (800) 323-9114
Email: sales@tksimplex.net
www.tksimplex.com

CANADIAN WAREHOUSE
637 McCaffrey
St. Laurent, PQ H4T1N3
Phone: (514) 731-4893
Fax: (514) 731-7457
Toll Free: (800) 840-1196
Email: info@ips-serv.com

EUROPEAN WAREHOUSE
Economiestraat 39, Unit 8
6433 KC, Hoensbroek, Netherlands
Phone: +31-45-5234545
Fax: +31-45-5234556
Email: info@tksimplex.nl
www.tksimplex.nl

ASIA & PACIFIC RIM
Phone: +612-9736-1619
Fax: +612-9736-2170
Email: fcimentit@tksimplex.net

MEXICO SOUTH
Phone: +52-55-2163 0630
Fax: +52-55-2163 0636

MEXICO NORTH
Phone: +52-81-8135-8207
Fax: +52-81-8135-8208

CHILE
Phone: +56-2-238-1112
Fax: +56-2-238-2695

MIDDLE EAST
Phone: +32-10-223322
Fax: +32-10-229444
omourrah@tksimplex.net

SOUTH AFRICA
Phone: +27-11-908-1721
Fax: +27-11-908-5806

SIMPLEX HYDRAULIC CYLINDERS



SIMPLEX HYDRAULIC PUMPS



SC103B

***Simplex General Catalog
Offers a complete line of rams, power
pumps hydraulic and mechanical jacks,
tools and accessories.***



www.tksimplex.com

DISTRIBUTED BY: