

VERSA-PAK

REFUSE PUMP SYSTEM

*The totally versatile
front mount system
for the refuse industry*



Versa-Pak Pump

- Permco uses only "controlled stress" roller bearings which last a minimum of 30% longer than standard roller bearings under the same conditions.
- All units are 100% factory tested.
- Dowel pin construction is standard.
- Solid one piece gear and shaft set with sealed outboard bearing which is protected with an outer shield keeping contamination away from the pump, reducing expensive downtime.
- Bleed valve built into the port end cover which eliminates the need for remote mounted bleed valves. (Dry Valve Version)
- Flows to 85 GPM / pressures to 3000 PSI.

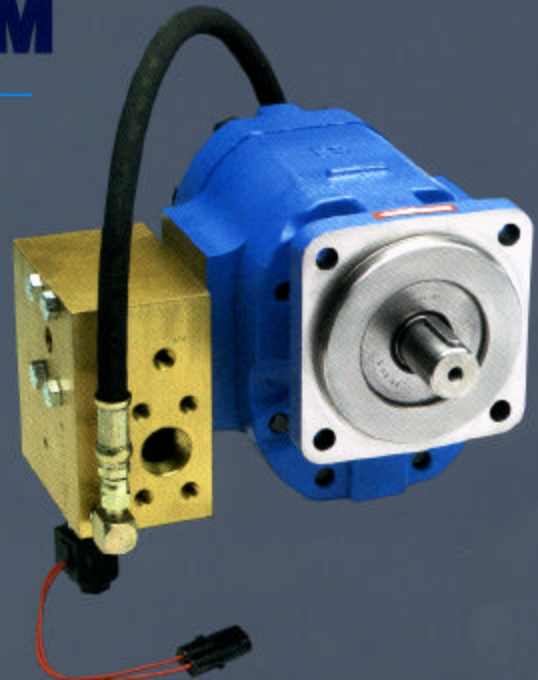

Versa-Pak Valve

- Two configurations available: One for an unloader system and one for a dry valve system.
- The flow control portion of the Versa-Pak Valve protects the system from hydraulic overspeed thus reducing expensive repairs and downtime
- The "Unloader" configuration has both the flow control and an Unloader function. By flipping a switch on the dash, the operator can go into the "stand-by mode" when there is no need for the hydraulic system to operate.
- Individual components make it easier to maintain and less expensive to repair
- No need for special directional control valves with signal lines
- The operator never loses control of the hydraulic system unlike other systems with other types of overspeed controls
- Tamper-resistant flow regulation yet field adjustable

The **VERSA-PAK** From



THE VERSA-PAK PUMP

We know you have choices when it comes to specifying hydraulic pumps. But with the innovative design features you'll find on the Versa-Pak Pump your decision just got easier. Like **LONGER PUMP LIFE** because we've increased bearing and shaft bearing surfaces. **SEALED OUTBOARD BEARING** with **PROTECTIVE SHIELD** which keeps out contamination before it gets to the bearing. Other features include **3 PIECE CAST IRON CONSTRUCTION** for extreme durability. **DOWEL PINS** for superior protection against pressure spikes. **SOLID ONE PIECE GEAR** and **SHAFT SET** for added strength. The **VERSA-PAK PUMP** has all the options as well. It comes in 5 sizes and offers a variety of shafts and mounting flanges. So whether this is the original installation or you're replacing an old worn out pump, it makes sense to install the **VERSA-PAK PUMP** from PERMCO.

The Sensible Choice

THE INSIDE STORY

Permco's newest line of mobile pumps can achieve up to 30% longer life with the patented controlled stress roller bearings. This advanced design distributes internal bearing loads more evenly for lower stress levels. Reduced stress can minimize damage to the gear hubs and extend service life. The bearings are designed to handle extreme hub bending and resulting stresses caused by system pressure. In conventional pumps, these stresses cause spalling damage that creates metal flaking and an undesirable clearance within the bearings. In extreme cases, the resulting gear hub flex allows the gear teeth to make excessive contact with

the housing, causing material removal and premature pump failure. Permco's

new mobile pumps provide reliable performance with reduced maintenance costs. With less contamination from spalling and machining particles, the hydraulic fluid remains cleaner, effectively preventing damage to other components in the hydraulic system.



PERMCO

1500 Frost Rd
Streetsboro, OH 44241

Phone (330) 626-2801
Fax (330) 626-2805

Mount System from Permco



THE VERSA-PAK VALVE

The VERSA-PAK Valve is available in two configurations. The first configuration, most commonly used with a Dry Valve System, functions as a pressure compensated **FLOW CONTROL**. This limits flow to the hydraulic system allowing a preset amount to the system with the excess flow being returned back to tank at low pressure. Because the system's main relief valve isn't flooded, it can better accomplish its function of controlling the system pressure. This reduces repairs and downtime associated with overspeeding and overpressurizing the hydraulic system. Because the system never exceeds the correct flow, it doesn't have the consequential pressure spikes resulting in cylinder and component failure. Also, the excess flow is plumbed back into the Dry Valve, thus reducing the possibility of cavitating the pump at high RPM. All this means less downtime and greater cost savings.

The second configuration includes both the flow control and an **"UNLOADER"**. The Unloader, normally used without a Dry-Valve, diverts 100% of the flow back to tank at extremely low pressure. By activating a switch, the operator can go into the "stand-by mode" when there is no need for the hydraulic system. Even though the pump sees full flow at all times, the horse power consumption is greatly reduced compared to what is normally associated with "wet" systems. Additionally, with the VERSA-PAK System, the operator, though unable to overspeed the hydraulic system, is **ALWAYS** in control, unlike other systems which have electronic or hydraulic overspeed controls. All this adds up to **INCREASED REVENUES** and **REDUCED OPERATING COSTS!**

DRY VALVES

Permco's air operated Dry Valve permits solid waste compaction while the vehicle is underway, creating maximum efficiency of the operator and equipment. It also reduces fuel consumption during the "off" mode. At the same time, it eliminates heat build-up in the hydraulic system associated with large flows when the system is not in use. The Dry Valve is easily operated by a dash mounted electric over air switch or manual air valve. It is available in either 1 1/2" or 2" four bolt split flange and includes breather vent, tubing and fittings.

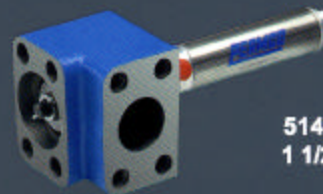

514-00911-DVA
1 1/2" Dry Valve



514-00278-DVA
2" Dry Valve

Versa-Pak Pump Model Number Construction

VP42 - 4C 0 F L UL

PUMP MODEL (VP+GPM @ 1200 RPM)

- VP28
- VP32
- VP37
- VP42
- VP47

MOUNTING FLANGE

- 4B FOUR BOLT "B"
- 2C TWO BOLT "C"
- 4C FOUR BOLT "C"

SHAFT

- 0 1 1/4" C KEYED
- 6 1 1/4" C SPLINE

FUNCTION

- UL UNLOADER
- DV DRY VALVE

ROTATION

- L LEFT, CCW
- R RIGHT, CW

PORTS

VP28, VP32
1 1/2" X 1 1/4" SPLIT FLANGE

VP37, VP42, VP47
2" X 1 1/4" SPLIT FLANGE

For additional options contact Permco or your local Permco distributor.

Versa-Pak Valve Model Number Construction

VP100 - U 45 S H1

VALVE MODEL

VP100

UNLOADER

- U UNLOADER INSTALLED
- C FLOW CONTROL ONLY
- K KIT ONLY (NON-FUNCTIONAL - DOES NOT INCLUDE SOLENOID, SOLENOID PLUG, T1 PORT PLUG, OR REGULATED FLOW ORIFICE)

FLOW CONTROL SETTING (GPM)

- BL = NO ORIFICE
- 30, 35, 40, 45, 50,
- 55, 60, 65, 70, 75, 80

HOSE KIT

- H1 EXCESS FLOW HOSE KIT
3/4" (USE WITH DRY VALVE)
- H2 SOLENOID DRAIN HOSE KIT
3/8" (USE WITH UNLOADER)
- X1 NO HOSE KIT INCLUDED

SWITCH KIT

- S SWITCH KIT INCLUDED FOR UNLOADER OPTION ONLY
- X NO SWITCH KIT INCLUDED

Versa-Pak Pump Specifications

Model Number	Displ. Cu. In.	Max. RPM	Min. RPM	Max. PSI	Inlet Port SAE 4 Bolt	Discharge Port SAE 4 Bolt
VP28	6.066	3000	600	3000	1-1/2"	1 1/4"
VP32	7.077	3000	600	3000	1-1/2"	1 1/4"
VP37	8.088	3000	600	2500	2"	1 1/4"
VP42	9.099	2500	600	2500	2"	1 1/4"
VP47	10.110	2500	600	2250	2"	1 1/4"



1500 Frost Rd
Streetsboro, OH 44241

Phone (330) 626-2801
Fax (330) 626-2805

DIMENSIONAL DATA (inches)

SAE "C" 4 BOLT 5" Pilot

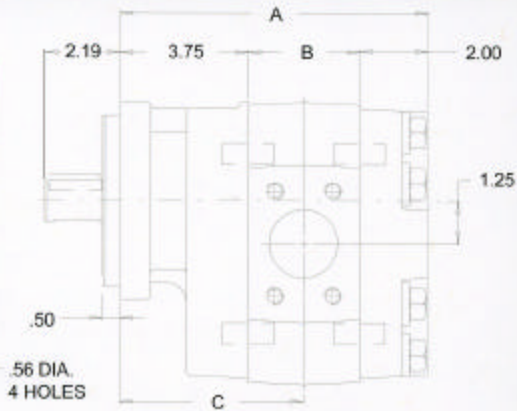

FOR ALL PUMPS

	A	B	C
VP28	8.25	2.50	5.00
VP32	8.50	2.75	5.12
VP37	8.75	3.00	5.25
VP42	9.00	3.25	5.38
VP47	9.25	2.50	5.50

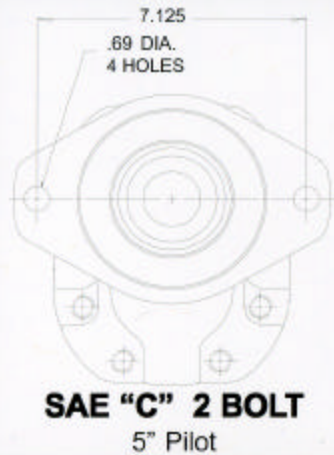

SAE "B" 4 BOLT 4" Pilot

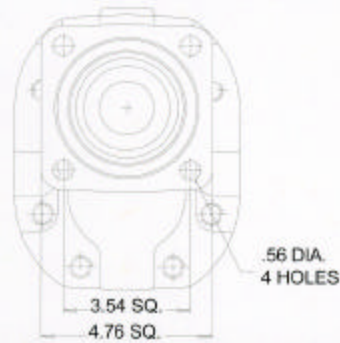

SAE "C" 2 BOLT 5" Pilot

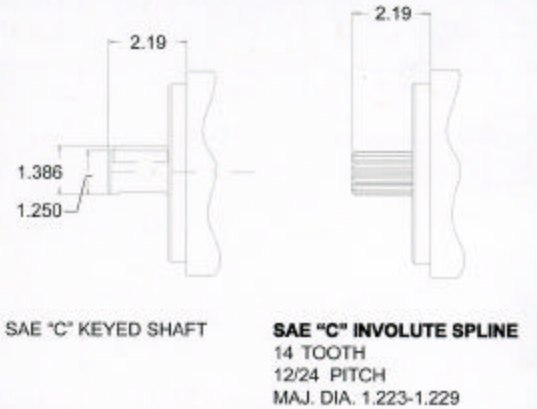

SAE "C" KEYED SHAFT

SAE "C" INVOLUTE SPLINE
14 TOOTH
12/24 PITCH
MAJ. DIA. 1.223-1.229

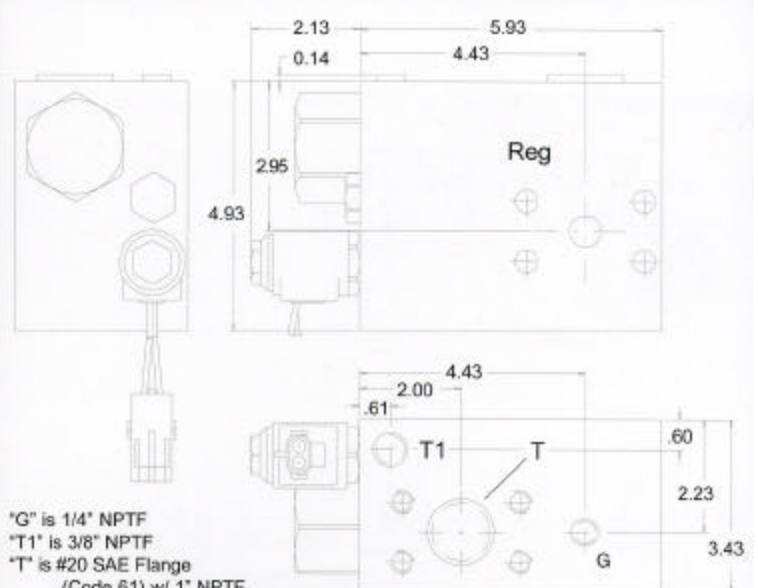
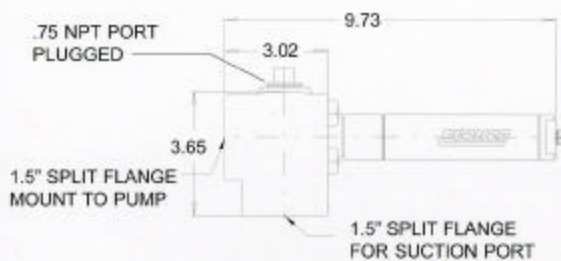
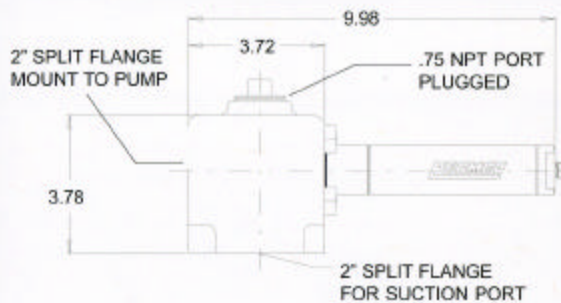

"G" is 1/4" NPTF
 "T1" is 3/8" NPTF
 "T" is #20 SAE Flange (Code 61) w/ 1" NPTF
 "P" is #20 SAE Flange (Code 61) w/ O-ring Groove (Opposite "Reg")
 "Reg" is #20 SAE Flange (Code 61)

ACCESSORIES

UNLOADER APPLICATIONS



Solenoid Drain Hose Kit

PART No. 999-00946 Simplify installation of the Unloader with this hose kit. The kit consists of one 3/8" hose assembly and fittings.



Electric Switch Kit for Versa-Pak Unloader

PART No. 999-00953

The Switch Kit provides for easy operation and installation of cab controls. The kit includes switch/light, switch bracket, wire, fuse, and connectors.



Solenoid for Versa-Pak Unloader

PART No. 999-00948

Use this Solenoid to convert the Versa-Pak Valve Kit to a functional Unloader Valve.

You will also need the proper orifice.

DRY VALVE APPLICATIONS

Electric/Air Shift Kit for Dry Valve

PART No. 999-00954. The Switch Kit provides for easy operation and installation. The kit includes electric/air solenoid, switch/light, bracket, wire, connectors, pressure protection valve, tubing, and fittings.



Excess Flow Hose Kit

PART No. 999-00945. Excess flow is returned to the Dry Valve for easy installation and also assists in the reduction of cavitation at high RPM. The kit consists of one 3/4" hose assembly and fittings.

Conversion Kit for Versa-Pak Flow Control

PART No. 999-00955. The Kit provides for easy conversion of Versa-Pak Valve Kit to the Flow Control Function. Kit includes solenoid port plug and T1 port plug. **You will also need the proper orifice.**



ADDITIONAL REFUSE INDUSTRY RELATED PRODUCTS



CH Series Gear Pumps

CH Series pumps are available in three sizes: 3.84, 5.12, and 6.40 cubic inches. They are pad mounted with dual 1 1/8" keyed shafts. All CH Series pumps come with a 1 1/2" NPT inlet port. The CH384-15 and CH512-20 each have 3/4" ODT discharge ports and the CH640 has a 1" ODT discharge port.



P3000 and P5000 Series Roller Bearing Pumps

Built tough to withstand the rough service commonly associated with the refuse industry. Typical applications include recycle vehicles, compactors, roll-offs, automated side loaders, and all PTO driven pump applications. P3000's and P5000's are available in a wide variety of configurations including Dry Valve and Unloader Applications.

Port Adapter Kit

PART No. 514-00952 1 1/2"
PART No. 514-00951 2"
Quickly and easily converts Pump without "counterbored" inlet port to fit applications where counterboring is necessary.



Orifice Plug

PART No. 999-00949-(XX)
Last two digits represent GPM. Insert in Versa-Pak Valve Kit to deliver proper flow to regulated port. See installation manual for proper sizing.

