



FLOW DIVIDERS / PRESSURE INTENSIFIERS

FD2100/3000/3100, FD5000/5100, FD7500/7600

SERIES



FLOW EQUALIZER * FLOW DIVIDER * PRESSURE INTENSIFIER

This catalog contains the information needed to apply and specify a Permco flow divider or intensifier for your hydraulic system. These units were developed by Permco to serve the industrial and mobile market. All units are manufactured from cast iron and incorporate crowned roller bearings and stackable construction.

This catalog is divided into (1) performance and (2) ordering information. Contained within one (1) flow rates, basic equations, overall dimensions etc., can be found. Part two (2) is divided into the individual components which will be combined to suit your particular application. The sections follow in the same sequence as a Permco flow divider or intensifier is coded.

This engineering catalog does not include the entire line. Other types as well as porting arrangements are available. Please contact your distributor, factory authorized service center or Permco's Customer Service for further information.

**FD2100/3000/3100, FD5000/5100
FD7500/7600
FLOW DIVIDERS AND INTENSIFIERS**

The two devices discussed in this brochure are typically constructed of the same components. It is only through their placement in a hydraulic system that one may discern whether the device is a flow divider or an intensifier.

A flow divider accepts flow and then internally divides or combines it. This division may be equal (such as 50 GPM being divided into 25 GPM and 25 GPM) or unequal (such as 50 GPM being divided into 12.5 GPM and 37.5 GPM). In turn, this device may have more than two (2) outlet ports whereby inlet flow may be divided by three (3) (such as 60 GPM being divided into three (3) equal outputs) or more. Almost any type of division of inlet flow can be achieved by selecting the correct number of gears and correct gear width.

Rotary intensifiers on the other hand divide flow to increase pressure. This enables part of the hydraulic system to work at pressure higher than the relief valve setting at the pump. Since the two devices are really one in the same, the flow dividers described above may become intensifiers. Relief valves downstream of the intensifiers are recommended.

By using these devices, you may simplify circuitry, increase the life of components and thereby reduce cost. The following describes the function and application of the FD2100/3000/3100, FD5000/5100 & FD7500/7600 flow dividers which are assembled using Permco service proven gear pump components.

FUNCTION:

Flow dividers are components in a hydraulic circuit which work only when needed and only to the extent required. Their job function is to accept flow and divide it (equally or unequally) or to combine flow in the reverse direction. They function by the principle that input fluid

horsepower equals output fluid horsepower, minus the small inefficiency of the flow divider itself.

In rotary intensifiers, one of the output ports operates at a lower pressure than inlet. This gear section of the intensifier (or flow divider) now acts as a motor providing power through the connecting shaft to the other gear sections. To reiterate, with one outlet of a two (2) section device operating at a lower pressure than inlet, the outlet can perform against a pressure higher than inlet, thus providing the intensifier function of the unit.

Both rotary flow dividers and intensifiers divide flow and distribute pressure according to the individual system requirements. The total output flow of the component is equal to its inlet flow. The output of each section is directly proportional to the gear width of the section.

BASIC SIZING REQUIREMENTS:

The most efficient gear widths are one (1") inch or larger. The most efficient speed (RPM) range is from 700 to 1400 RPM. Higher RPM's will increase the sound pressure level of the unit. Units with all gear widths of 1/2" and 3/4" should be avoided.

EXAMPLES: Units with 1/2" gears would work best with another section of a least 1-1/2". Units with 3/4" gears would work best with another section of a least 1-1/4".

In three (3) section units or larger, it is good practice to position the inlet port nearest the largest gear section. It is also recommended that the largest gear section be placed in the center of the unit.

For applications where speeds are below 500 RPM or above 1400 RPM, and/or where pressure across the unit may exceed 2000 PSI (138 Bar) for 3000, 5000 & 7500 series and 2500 PSI (172 Bar) for 2100, 3100, 5100 and 7600, please consult the factory.

FLOW DIVIDER SELECTION:

To select a flow divider, this procedure should be followed:

For equal flow division, select a gear width greater than one (1") inch from the charts keeping the speed between about 700 RPM and 1400 RPM.

For unequal flow division use the following procedure:

- 1) Determine the outlet flow required for each leg of the hydraulic circuit.
- 2) Use charts below to select a series and gear width for the leg with the greatest flow (keeping gear widths greater than one (1") inch).
- 3) Move straight up the chart to select the other gear widths by choosing gear widths with the closest flow at the same RPM.
- 4) Check the actual flow for each section to determine if acceptable using the following formula.

$$\text{GEAR WIDTH} / (\text{TOTAL GEAR WIDTH}) \times \text{TOTAL FLOW} = \text{FLOW FOR SECTION}$$

- 5) If the flows are not acceptable, repeat from step (2) by choosing a different gear width or moving to a chart in another series.

EXAMPLE:

- 1) System requires flows of 35 GPM and 20 GPM for a total of 55 GPM.
- 2) Select a 2-1/2" gear in the FD5000 series in 1300 RPM column.
- 3) Note: 1-1/2" gear and 1-1/4" gear both are about the same difference from 20 GPM therefore we will consider both.
- 4) Using 2-1/2" and 1-1/4" gears the output would be:

$$\begin{aligned} \text{TOTAL GEAR WIDTH IS } 1.25 + 2.50 &= 3.75 \\ (1.25/3.75) * 55 &= 18.3 \text{ GPM} \\ (2.50/3.75) * 55 &= 36.6 \text{ GPM} \end{aligned}$$

$$\begin{aligned} \text{TOTAL GEAR WIDTH IS } 1.50 + 2.50 &= 4.00 \\ (1.50/4.00) * 55 &= 20.6 \text{ GPM} \\ (2.50/4.00) * 55 &= 34.3 \text{ GPM} \end{aligned}$$

- 5) Check to determine which combination of flows is best for the application.

SERIES FLOW CHART

FD2100/3000/3100

GEAR WIDTH	RPM	RPM	RPM	RPM	RPM	RPM	RPM	RPM
	700	800	900	1000	1100	1200	1300	1400
0.50	3.0	3.4	3.8	4.3	4.7	5.1	5.5	6.0
0.75	4.5	5.1	5.8	6.4	7.0	7.7	8.3	9.0
1.00	6.0	6.8	7.7	8.5	9.4	10.2	11.1	11.9
1.25	7.5	8.5	9.6	10.7	11.7	12.8	13.9	14.9
1.50	9.0	10.2	11.5	12.8	14.1	15.4	16.6	17.9
1.75	10.4	11.9	13.4	14.9	16.4	17.9	19.4	20.9
2.00	11.9	13.6	15.4	17.1	18.8	20.5	22.2	23.9

FD5000/5100

GEAR WIDTH	RPM	RPM	RPM	RPM	RPM	RPM	RPM	RPM
	700	800	900	1000	1100	1200	1300	1400
0.50	3.9	4.5	5.0	5.6	6.1	6.7	7.2	7.8
0.75	5.8	6.7	7.5	8.4	9.2	10.0	10.9	11.7
1.00	7.8	8.9	10.0	11.1	12.3	13.4	14.5	15.6
1.25	9.7	11.1	12.5	13.9	15.3	16.7	18.1	19.5
1.50	11.7	13.4	15.0	16.7	18.4	20.0	21.7	23.4
1.75	13.6	15.6	17.5	19.5	21.4	23.4	25.3	27.3
2.00	15.6	17.8	20.0	22.3	24.5	26.7	29.0	31.2
2.25	17.5	20.0	22.6	25.1	27.6	30.0	32.6	35.1
2.50	19.5	22.3	25.1	27.8	30.6	33.4	36.2	39.0

FD7500/7600

GEAR WIDTH	RPM	RPM	RPM	RPM	RPM	RPM	RPM	RPM
	700	800	900	1000	1100	1200	1300	1400
0.50	6.1	7.0	7.9	8.8	9.6	10.5	11.4	12.3
0.75	9.2	10.5	11.8	13.1	14.4	15.8	17.1	18.4
1.00	12.3	14.0	15.8	18.5	19.3	21.0	22.8	24.5
1.25	15.3	17.5	19.7	21.9	24.1	26.3	28.4	30.6
1.50	18.4	21.0	23.6	26.3	28.9	31.5	34.1	36.8
1.75	21.4	24.5	27.6	30.6	33.7	36.8	39.8	42.9
2.00	24.5	28.0	31.5	35.0	38.5	42.0	45.5	49.0
2.25	27.6	31.5	35.5	39.4	43.3	47.3	51.2	55.1
2.50	30.6	35.0	39.4	43.8	48.1	52.5	56.9	61.3
2.75	33.7	38.5	43.3	48.1	53.0	57.8	62.6	67.4
3.00	36.8	42.0	47.3	52.5	57.8	63.0	68.3	73.5

INTENSIFIER SELECTION:

An intensifier is constructed in the same manner as a flow divider. However, in an intensification circuit one section of the intensifier has an operating pressure at its outlet port below the pressure at the inlet port. This section then functions as a motor, supplying the necessary torque to the second section which based on downstream pressure higher than that of the inlet port.

EXAMPLE:

Given available flow of 50 GPM at 1500 PSI, determine gears for a unit to intensify 35 GPM to 2500 PSI.

- 1) First determine if output is possible by calculating input and output horsepower.
 $HP = [GPM \times PSI] / [1714]$
 $HP\ IN = [50 \times 1500] / [1714] = 43.7\ HP$
 $HP\ OUT = [35 \times 2500] / [1714] = 51.1\ HP$
- 2) Determine gear ratio for intensifier.
 Since chart shows theoretical ratios we will add inefficiency in here.
 $REQUIRED\ PSI = [ACTUAL\ PSI / .9]$
 $[2500\ PSI / .9] = 2777\ PSI$

- 3) Find ratio for intensifier chart.
 $[REQUIRED\ PSI / ACTUAL\ PSI] = RATIO$
 $[2777 / 1500] = 1.85$
- 4) Find closest ratio from RATIO CHART.
 Chart shows the closest match to be a 1.75" gear loaded and a 1.5" gear unloaded to tank.
- 5) Find flows for each section as follows:
 Flow for section =
 $[GEARWIDTH / TOTAL\ GEARWIDTH] \times TOTAL\ FLOW$
 $[1.5 / (1.5 + 1.75)] \times 50 = 23.1\ GPM\ UNLOADED$
 $[1.75 / (1.5 + 1.75)] \times 50 = 26.9\ GPM\ LOADED$
- 6) Now use the flow divider chart and size a flow divider for the calculated flows. From the chart we find that a FD5000 with 1.75" and 1.50" gear will spin at about 1400 RPM and a FD7500 with the same size gears will operate at about 900 RPM.

RATIO CHART FOR INTENSIFICATION (THEORETICAL)

GEAR ACROSS THE TOP SHOWS SECTION GOING BACK TO TANK @ 0 PSI

	0.50	0.75	1.00	1.25	1.50	1.75	2.00	2.25	2.50	2.75	3.00
LOAD GEAR											
0.50	2.00	2.50	3.00	3.50	4.00	4.50	5.00	5.50	6.00	6.50	7.00
0.75	1.67	2.00	2.33	2.67	3.00	3.33	3.67	4.00	4.33	4.67	5.00
1.00	1.50	1.75	2.00	2.25	2.50	2.75	3.00	3.25	3.50	3.75	4.00
1.25	1.40	1.60	1.80	2.00	2.20	2.40	2.60	2.80	3.00	3.20	3.40
1.50	1.33	1.50	1.67	1.83	2.00	2.17	2.33	2.50	2.67	2.83	3.00
1.75	1.29	1.43	1.57	1.71	1.86	2.00	2.14	2.29	2.43	2.57	2.71
2.00	1.25	1.38	1.50	1.63	1.75	1.88	2.00	2.13	2.25	2.38	2.50
2.25	1.22	1.33	1.44	1.56	1.67	1.78	1.89	2.00	2.11	2.22	2.33
2.50	1.20	1.30	1.40	1.50	1.60	1.70	1.80	1.90	2.00	2.10	2.20
2.75	1.18	1.27	1.36	1.45	1.55	1.64	1.73	1.82	1.91	2.00	2.09
3.00	1.17	1.25	1.33	1.42	1.50	1.58	1.67	1.75	1.83	1.92	2.00

ORDERING INFORMATION

The assembly code of the flow divider is similar to the pump code in that individual code, for gear housings, port end covers, and bearing carriers combine in sequence to make up the complete assembly code of the unit.

EXAMPLE:

A flow divider assembly code: FD3000BAXDC12-1EDC12AX

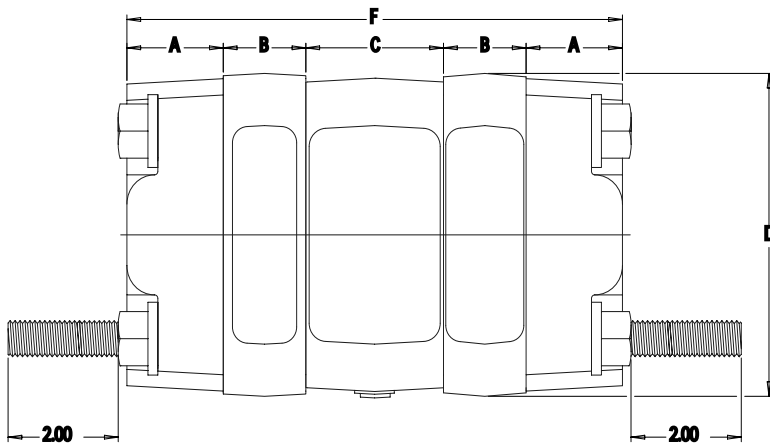

CODE EXAMPLE: 3000 SERIES

FLOW DIVIDER	_____	FD
SERIES	_____	3000
MULTIPLE	_____	B
PORT END COVER	_____	AX
GEAR HOUSING	_____	DC12
CONNECTING SHAFT	_____	1
BEARING CARRIER	_____	E
GEAR HOUSING	_____	DC12
PORT END COVER	_____	AX

SERIES	TWO SECTION				THREE SECTION	FOUR SECTION	FIVE SECTION	
	"A" DIM	"B" DIM	"C" DIM	"D" DIM	"F" DIM	"F" DIM	"F" DIM	
FD3000	1.75 44,4	.75+GW 19,0+GW	2.50 63,5	5.50 139,7	7.50+TOTGW 190,5+TOTGW	10.75+TOTGW 273,0+TOTGW	14.00+TOTGW 355,6+TOTGW	17.25+TOTGW 438,2+TOTGW
FD5000	1.75 44,4	.75+GW 19,0+GW	2.88 73,0	6.25 158,7	7.88+TOTGW 200,0+TOTGW	11.50+TOTGW 292,1+TOTGW	15.12+TOTGW 384,2+TOTGW	18.75+TOTGW 476,3+TOTGW
FD7600	2.00 50,8	1.00+GW 25,4+GW	3.00 76,2	203,2	9.00+TOTGW 228,6+TOTGW	13.00+TOTGW 330,2+TOTGW	17.00+TOTGW 431,8+TOTGW	21.00+TOTGW 533,4+TOTGW

Dimensions are in inches
MM

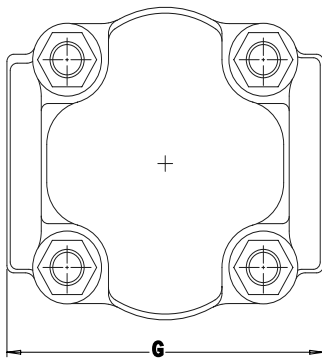

SERIES	"G1" DIM	"G2" DIM	"G3" DIM	"G4" DIM	"G5" DIM
FD3000	5.18 131,6	5.75 146,0	5.75 146,0	5.75 146,0	5.62 142,7
FD5000	5.18 131,6	5.75 146,0	5.75 146,0	5.75 146,0	5.62 142,7
FD7600	7.37 187,2	7.37 187,2	7.37 187,2	7.37 187,2	7.25 184,1

Dimensions are in inches
MM

- G1= Narrow Bearing Carrier with no ports
- G2= Wide Bearing Carrier with no ports
- G3= Wide Bearing Carrier with Straight Thread Ports
- G4= Wide Bearing Carrier with NPT Ports
- G5= Wide Bearing Carrier with Split Flange Ports

PORT END COVERS

FD3000/3100 SERIES

CODE SELECTION

NPT (in.)					
LEFT	B	RIGHT	A	STUDS/F	STUDS EXT.
~~~~	~~~~	~~~~	~~~~	AH	AX
3/4	1 1/4	~~~~	~~~~	JH	JX
~~~~	~~~~	3/4	1 1/4	KH	KX
3/4	1 1/4	3/4	1 1/4	LH	LX

CODE SELECTION

STRAIGHT THREAD (in.)					
LEFT	B	RIGHT	A	STUDS/F	STUDS EXT.
3/4	1 1/4	~~~~	~~~~	BH	BX
~~~~	~~~~	3/4	1 1/4	CH	CX
3/4	1 1/4	3/4	1 1/4	EH	EX
1*	1 3/8	3/4	1 1/4	FH	FX
3/4	1 1/4	1*	1 3/8	GH	GX
1*	1 3/8	1*	1 3/8	IH	IX

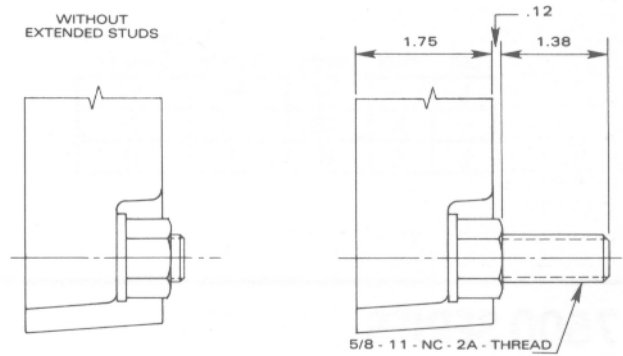
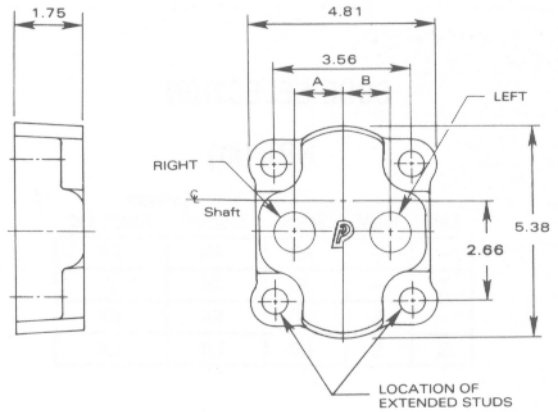

## FD5000/5100 SERIES

### CODE SELECTION

NPT (in.)			
LEFT	RIGHT	STUDS/F	STUDS EXT.
~~~~	~~~~	AH	AX
3/4	~~~~	JH	JX
~~~~	3/4	KH	KX
3/4	3/4	LH	LX

### CODE SELECTION

STRAIGHT THREAD (in.)			
LEFT	RIGHT	STUDS/F	STUDS EXT.
3/4	~~~~	BH	BX
~~~~	3/4	CH	CX
3/4	3/4	EH	EX
1*	3/4	FH	FX
3/4	1*	GH	GX
1*	1*	IH	IX

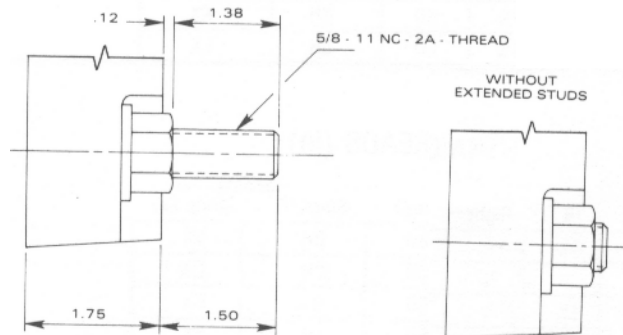
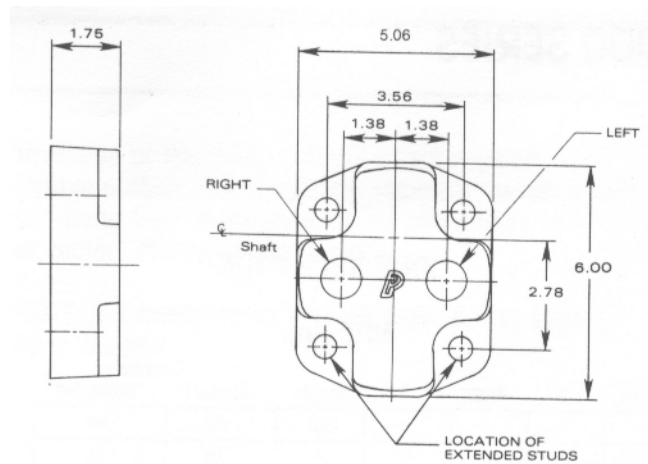

*MAXIMUM PRESSURE 2000 PSI (140BAR)

PORT END COVERS

FD7000/7600 SERIES

CODE SELECTION

NPT (in.)			
LEFT	RIGHT	STUDS/F	STUDS EXT.
~~~	~~~	AH	AX
3/4	~~~	JH	JX
~~~	3/4	KH	KX
3/4	3/4	LH	LX

CODE SELECTION

STRAIGHT THREAD (in.)			
LEFT	RIGHT	STUDS/F	STUDS EXT.
3/4	~~~	BH	BX
~~~	3/4	CH	CX
3/4	3/4	EH	EX
1	3/4	FH	FX
3/4	1	GH	GX
1	1	IH	IX

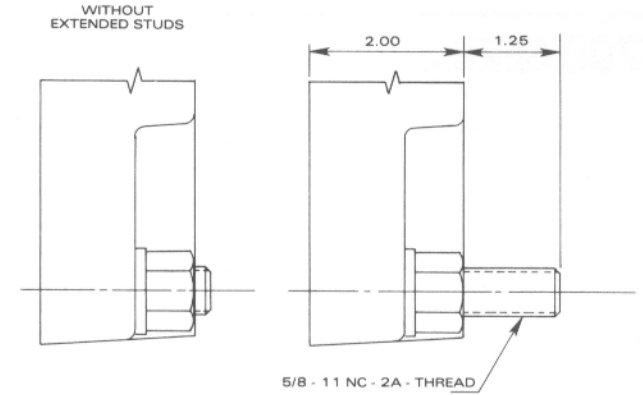
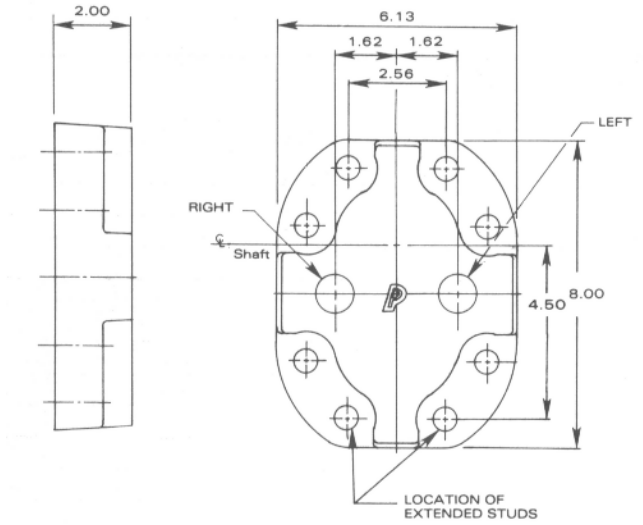

## GEAR HOUSINGS

**FD3000/3100**

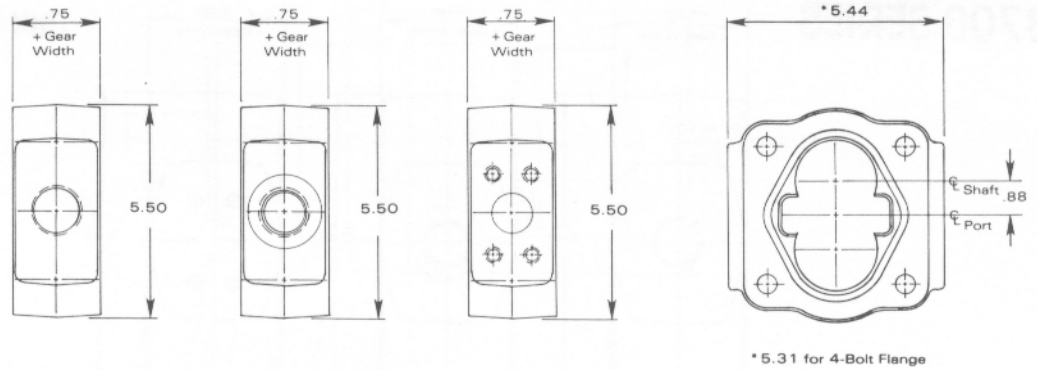

### CODE SELECTION GEAR WIDTH (in.)

N.P.T. DIAMETER (in.)								
LEFT	RIGHT	1/2	3/4	1	1 1/4	1 1/2	1 3/4	2
NONE	NONE	ZA05	ZA07	ZA10	ZA12	ZA15	ZA17	ZA20
NONE	3/4			HC10	HC12	HC15	HC17	HC20
NONE	1				XC12	XC15	XC17	XC20
1	3/4				HI12	HI15	HI17	
1 1/4	1						XI17	XI20

### CODE SELECTION GEAR WIDTH (in.)

4-BOLT FLANGE DIAMETER (in.)								
LEFT	RIGHT	1/2	3/4	1	1 1/4	1 1/2	1 3/4	2
NONE	NONE	ZA05	ZA07	ZA10	ZA12	ZA15	ZA17	ZA20
NONE	3/4			TC10	TC12	TC15	TC17	TC20
NONE	1				NC12	NC15	NC17	NC20
1	3/4				TI12	TI15	TI17	
1 1/4	1					NI15	NI17	NI20

### CODE SELECTION GEAR WIDTH (in.)

STRAIGHT THREAD DIAMETER (in.)								
LEFT	RIGHT	1/2	3/4	1	1 1/4	1 1/2	1 3/4	2
NONE	NONE	ZA05	ZA07	ZA10	ZA12	ZA15	ZA17	ZA20
NONE	3/4			DC10	DC12	DC15	DC17	DC20
NONE	1					ZC15	ZC17	ZC20
1*	3/4				DI12*	DI15	DI17	
1 1/4*	1						ZI17*	ZI20

* MAXIMUM PRESSURE 2000 PSI (140 BAR)

## GEAR HOUSINGS

### FD5000/5100

A = 5.61 FOR GEAR WIDTHS UP TO 2-1/4"  
6.94 FOR 2-1/4" AND 2-1/2"  
GEAR WIDTHS

4-BOLT FLANGE

A = 5.31 FOR GEAR WIDTHS UP TO 2-1/4"  
6.62 FOR 2-1/4" AND 2-1/2"  
GEAR WIDTHS

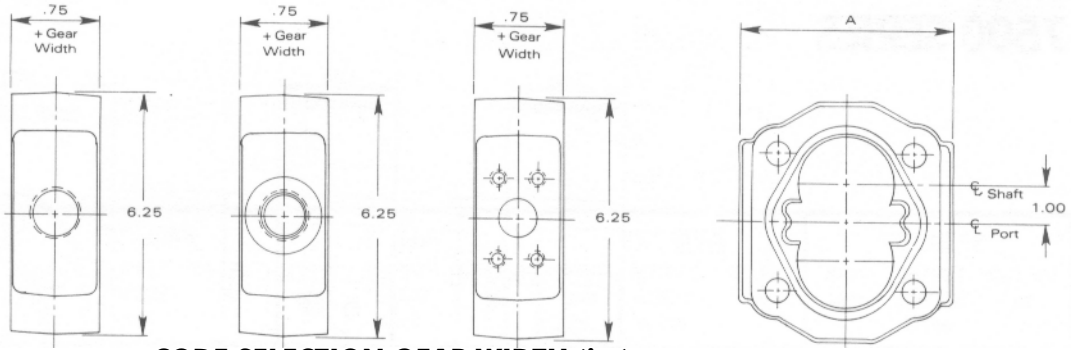

**CODE SELECTION GEAR WIDTH (in.)**

N.P.T. DIAMETER (in.)										
LEFT	RIGHT	1/2	3/4	1	1 1/4	1 1/2	1 3/4	2	2 1/4	2 1/2
NONE	NONE	ZA05	ZA07	ZA10	ZA12	ZA15	ZA17	ZA20	ZA22	ZA25
NONE	3/4			HC10	HC12	HC15	HC17	HC20		
1*	3/4			HI10*	HI12*	HI15	HI17	HI20		
NONE	1					XC15	XC17	XC20	XC22	
1 1/4	1							XI20	XI22	XI25
NONE	1 1/4							HA20	HA22	HA25

**CODE SELECTION GEAR WIDTH (in.)**

4-BOLT FLANGE DIAMETER (in.)										
LEFT	RIGHT	1/2	3/4	1	1 1/4	1 1/2	1 3/4	2	2 1/4	2 1/2
NONE	NONE	ZA05	ZA07	ZA10	ZA12	ZA15	ZA17	ZA20	ZA22	ZA25
1*	3/4				TI12*	TI15	TI17	TI20		
NONE	1*				NC12*	NC15	NC17	NC20	NC22	
1 1/4*	1					NI15*	NI17*	NI20	NI22	NI25
1 1/2	1 1/4								NO22	NO25
NONE	1 1/4*						NA17*	NA20	NA22	NA25

**CODE SELECTION GEAR WIDTH (in.)**

STRAIGHT THREAD DIAMETER (in.)										
LEFT	RIGHT	1/2	3/4	1	1 1/4	1 1/2	1 3/4	2	2 1/4	2 1/2
NONE	NONE	ZA05	ZA07	ZA10	ZA12	ZA15	ZA17	ZA20	ZA22	ZA25
NONE	3/4*			DC10*	DC12*	DC15	DC17			
1*	3/4						DI17*	DI20		
NONE	1*						ZC17	ZC20	ZC22	
1 1/4*	1							ZI20*	ZI22	ZI25

* MAXIMUM PRESSURE 2000 PSI (140 BAR)

## GEAR HOUSINGS

### FD7500/7600

STRAIGHT THREAD PORTS (JIC)  
PIPE PORTS (NPT) OR NO PORTS

A = 7.62 FOR GEAR WIDTHS 3/4" TO 1-1/2"  
7.81 FOR GEAR WIDTHS 1-3/4" TO 3"

4-BOLT FLANGE PORTS

A = 7.50 FOR GEAR WIDTHS 3/4" TO 1-1/2"  
7.56 FOR GEAR WIDTHS 1-3/4" TO 3"

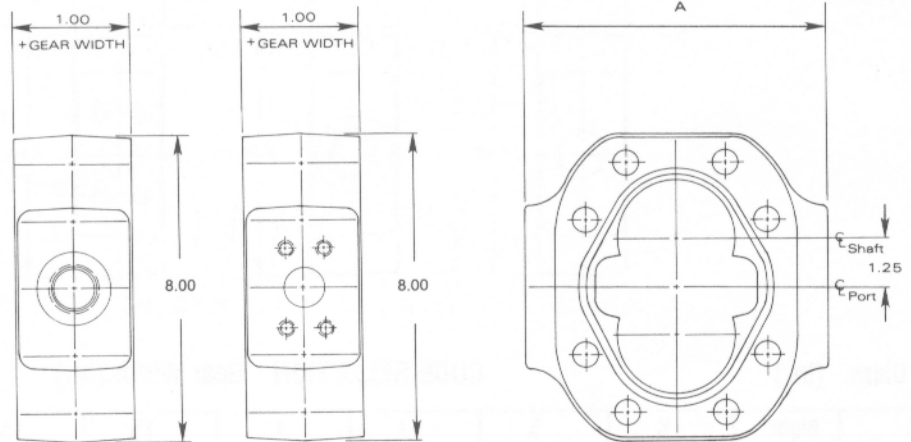

### CODE SELECTION GEAR WIDTH (in.)

4-BOLT FLANGE DIAMETER (in.)											
LEFT	RIGHT	3/4	1	1 1/4	1 1/2	1 3/4	2	2 1/4	2 1/2	2 3/4	3
NONE	NONE	ZA07	ZA10	ZA12	ZA15	ZA17	ZA20	ZA22	ZA25	ZA27	ZA30
1	3/4	TI07	TI10								
1	1		NE10	NE12	NE15	NE17	NE20				
1 1/4*	1		NI10	NI12							
1 1/4	1 1/4			NK12	NK15	NK17	NK20	NK22	NK25	NK27	NK30
1	1 1/2*			NG12	NG15						
1 1/2*	1 1/4			NO12	NO15	NO17	NO20				
1 1/2	1 1/2					NQ17	NQ20	NQ22	NQ25	NQ27	NQ30
1 1/4	2*					NM17	NM20	NM22	NM25	NM27	NM30
2*	1 1/2					NU17	NU20	NU22	NU25	NU27	NU30
2*	2*								NW25	NW27	NW30
1 1/2	2 1/2*								NS25	NS27	NS30
NONE	1 1/2					NT17	NT20	NT22			

### CODE SELECTION GEAR WIDTH (in.)

STRAIGHT THREAD DIAMETER (in.)											
LEFT	RIGHT	3/4	1	1 1/4	1 1/2	1 3/4	2	2 1/4	2 1/2	2 3/4	3
NONE	NONE	ZA07	ZA10	ZA12	ZA15	ZA17	ZA20	ZA22	ZA25	ZA27	ZA30
3/4	1	DF07									
1	3/4	DI07									
1	1		ZE10	ZE12	ZE15	ZE17	ZE20				
1 1/4	1 1/4					ZK17					

* MAXIMUM PRESSURE 2000 PSI (140 BAR)

BEARING CARRIER CODES

FD3000,FD5000,FD7500

SECTION  
A-A

BACK



FRONT

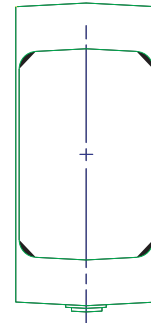
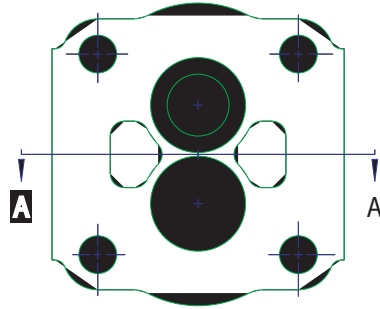

PORT SIZE  
LEFT RIGHT

PIPE  
THREAD

STRAIGHT  
THREAD

SPLIT  
FLANGE

	NONE	NONE	A	A	A
	NONE	NONE	D	D	D
	3/4 1 1-1/4 1-1/2	NONE NONE NONE NONE	P L M O	Q E F G	R I J K
	NONE NONE	3/4 1	AW JY	FI AJ	FQ LS
	NONE NONE	3/4 1	BU MJ	IG OB	EC IF
	1 1-1/4 1-1/2 1-1/4 1-1/2	3/4 3/4 3/4 1 1	FW GW QW KY SY	GI LI QI OJ QJ	GQ OQ PQ MS QS
	1 1-1/4 1-1/2 1-1/4 1-1/2	3/4 3/4 3/4 1 1	FU LU MU SJ YJ	OG QG VG PB UB	FC LC OC OF QF
	1	3/4	UF	LB	VK
	1	3/4	VF	RB	YK